

Series 10

Series 10

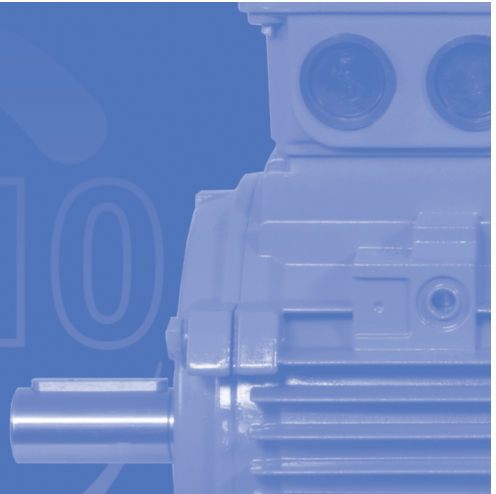

IE1 & IE2 Efficiency Ranges

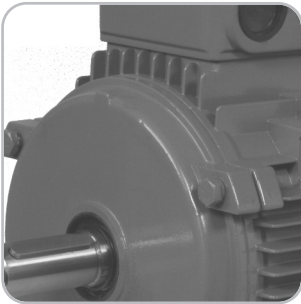

Introduction

2

Specification

| Specification | Standard product | Option |
|------------------------------------|------------------------------------|--|
| Frame material | 56- 160 aluminium | - |
| | 180 - 450 cast iron | - |
| Enclosure | IP55 | IP56, IP65 - (IE2 only) |
| Mounting option | Foot (B3), Flange (B5), Face (B14) | Foot & Flange (B35), Foot & Face (B34) |
| Terminal box position | Top | - |
| Voltage | 3 kW and below: 230 / 400 | - |
| | 4 kW and above: 400 / 690 | - |
| Frequency | 50 Hz | 60 Hz (IE1 only) |
| Cooling | IC411 | - |
| Bearing location | 56- 160 Non drive end | - |
| | 180 - 450 drive end - (IE2 only)* | - |
| | 180 - 450 non drive end | - |
| Lubrication | 56 - 160 double-shielded bearings | - |
| | 180 - 450 through greasing | - |
| Insulation | class F | - |
| Temperature rise | class B | - |
| Paint colour | water blue (RAL 5021) | - |
| Fan cover | Steel | - |
| Thermal protection - IE2 | 80 -112 - Thermostats | - |
| | 132 - 450 - Thermistors | - |
| Thermal protection - IE1 | 63 - 450 -Thermistors | - |
| Inverter Duty (with derate) | Variable Torque: 10:1 | - |
| | Constant Torque: 2:1 | - |
| Ambient temperature | -20°C to + 40°C | - |

The above specification and options give a brief summary of features available for the Series 10 range. For a full listing of optional features, please contact Brook Crompton sales.
* Where roller bearing is fitted, bearing is located at NDE

Brook Crompton

Brook Crompton is a leading provider of electric motors for the global industrial market.

Brook Crompton motors are used in almost every industrial activity including water treatment, building services, chemical/petrochemicals, general processing and manufacturing. They drive fans, pumps, compressors and conveyors.

Brook Crompton incorporates many well known names including Brook Motors, Crompton Parkinson, Electrodrives, Newman and Hawker Siddeley Electric Motors.

There are extensive stocks of motors, backed-up by a network of distributors, ensuring excellent local support wherever needed.

Quality assurance

Stringent quality procedures are observed from first design to finished product in accordance with the ISO9001 documented quality systems.

All factories have been assessed to meet these requirements.

Series 10

The Brook Crompton Series 10 range is a high quality standard range of electric motors with a specification suitable for most industrial applications.

It covers outputs from 0.06kW up to 900kW in frame sizes 56 to 450.

Benefits include:

- Full output range to meet your requirements
- Efficiencies are within the IE1 & IE2 bands (where applicable).
- Robust construction for long life
- Mountings: foot, flange, face or combination
- Multi-mount - aluminium range
- Integrated feet cast iron 180 frame & above.
- Euro voltage: up to 3kW 230/400V; 4kW and above 400/690V
- Dual frequency (50 / 60Hz)^
- IP55
- Metal fan cover
- Metric entries
- Thermal protection fitted as standard
- Inverter duty

^ IE1 only

Standards

| Standards | |
|--|------------------------|
| Series 10 motors are manufactured to the international standards listed below: | |
| Performance | IEC 60034-1 |
| Dimensions | IEC 60072-1 |
| Mounting | IEC 60034-7 |
| Enclosure protection | IEC 60034-5 |
| Vibration | IEC 60034-14 (grade A) |
| Noise | IEC60034-9 |

Environment Enclosure

All motors have degrees of IP protection as defined in IEC EN 60034-5. The normal arrangement is IP55. See Specification (page 2) for alternatives.

Motor cooling

Motors are cooled in accordance with IEC 60034-6. The normal arrangement is IC411 (Totally Enclosed Fan Ventilated) via a fan mounted at the non-drive end. See Specification (page 2) for alternatives.

European directives

The following European directives apply:

Directives

| Compliance with European directives applying to AC induction motors | | | | |
|---|---|---|---|---|
| Directives | Low voltage (LV) | Machinery (MD) | Electromagnetic compatibility (EMC) | Energy using products (EuP) |
| Reference numbers | 73/23/EEC 93/68/EEC 2006/95/EC | 2006/42/EC 98/79/EC 98/37/EC 93/44/EEC 89/392/EEC | 89/336/EEC 92/31/EEC 93/68/EEC 2004/108/EC | 92/42/EEC 96/57/EC 2000/55/EC 2005/32/EC |
| Motor CE marked | Yes | No | No | Yes |
| Standards | EN 60034 | Not applicable | EN 60034-1 | EN 60034-30 |
| Documentation for customers' technical file | Declaration of conformity | Certificate of incorporation | Statement ⁽¹⁾ | Declaration of conformity |
| Safety instructions with every motor | Yes | Yes | Yes | - |
| Comment | Relevant electrical equipment operating between 50 to 1000 volts AC | Statement ⁽²⁾ | Component | Minimum efficiency levels for motor outputs 0.75 - 375kW 2-6 pole |

⁽¹⁾ Motors operating from a correctly applied, sinusoidal (AC) supply meet the requirements of the EMC directive and are within the limits specified in standard EN 60034-1

⁽²⁾ When installed in accordance with our customer safety and installation and maintenance instructions, they can be put into service only when the machinery into which they are being incorporated, has been declared to be in conformity with the machinery directive in accordance with Article 4(2) and Annex IIB of that Directive (98/37/EEC)

Minimum Energy Performance Standard

The new standard

The EU MEPS scheme sets new **mandatory** minimum efficiency levels for most single speed 3ph induction motors up to 375kW rated up to 1000V, unlike the narrow definition of the CEMEP voluntary scheme which only covered a small number of standard motors.

The Voluntary Agreement, since 1998, of CEMEP for motor manufactures has now expired (classes EFF3 /EFF2/EFF1).

The new standard for motors is now **mandatory** regulation in Europe.

The scope of EU MEPS covers 2, 4 & 6 pole single speed 3ph induction motors from 0.75 to 375kW, rated up to 1000V based on continuous duty operation.

Aiming to reduce energy consumption throughout Europe and the rest of the world, it comes into effect in 3 stages. The effect of this is to maximise potential savings in electric motor driven systems. Base of the regulation is a new international IEC 60034-30 standard. It defines the following efficiency classes :

- IE1** - Standard Efficiency (comparable to EFF2)
- IE2** - High Efficiency (comparable to EFF1 and USA EPACT 60 Hz)
- IE3** - Premium Efficiency (comparable to USA "NEMA Premium" 60 Hz)

New Efficiency levels in Europe (Time Line)

Mandatory from:

From 16 June 2011:

Minimum efficiency requirement at IE2 for all motors covered 0.75 - 375kW

From 1 January 2015:

Minimum efficiency requirement at IE3 level for 7.5 - 375kW motors or IE2 level for motors equipped with an appropriate variable speed drive.

From 1 January 2017:

Minimum efficiency requirement at IE3 level for 0.75 - 375kW motors or IE2 level for motors equipped with an appropriate variable speed drive.

Performance data

IE1

4 3000 min⁻¹ (2 pole)

Rated power
Full load speed in revolutions per minute
Frame reference and size
Full load current at rated voltage
Efficiency
Power factor
Full load torque
Direct on line starting torque ratio
Direct on line pull up torque
Direct on line pull out torque
Direct on line starting current ratio
Rotor inertia Wk²
Mean sound pressure level (a 1m on no load)
Weight

| P _N | | n min ⁻¹ | Type | I _N | | | h 1.0 P _N | Cos Ø 1.0 P _N | M _N Nm | M _A M _N | M _S M _N | M _K M _N | I _A I _N | J kgm ² | L _{PA} dB(A) | kg |
|----------------|------|------------------------|------------|----------------|------------|------------|-------------------------|-----------------------------|----------------------|----------------------------------|----------------------------------|----------------------------------|----------------------------------|-----------------------|--------------------------|------|
| kW | hp | | | 380 V A | 400 V A | 415 V A | | | | | | | | | | |
| 0.09 | 0.15 | 2750 | B-DA56MA | 0.32 | 0.30 | 0.29 | 62.0 | 0.70 | 0.31 | 2.1 | - | 2.2 | 5.2 | 0.00018 | - | 3.6 |
| 0.12 | 0.20 | 2750 | B-DA56MB | 0.38 | 0.36 | 0.32 | 67.0 | 0.72 | 0.41 | 2.1 | - | 2.2 | 5.2 | 0.00023 | - | 3.9 |
| 0.18 | 0.25 | 2720 | B-DA63MA | 0.53 | 0.50 | 0.48 | 65.0 | 0.80 | 0.61 | 2.2 | - | 2.3 | 5.5 | 0.00031 | - | 4.8 |
| 0.25 | 0.33 | 2720 | B-DA63MB | 0.69 | 0.66 | 0.63 | 68.0 | 0.81 | 0.96 | 2.2 | - | 2.3 | 5.5 | 0.0006 | - | 5.1 |
| 0.37 | 0.5 | 2740 | B-DA71MA | 0.99 | 0.94 | 0.91 | 70.0 | 0.81 | 1.26 | 2.2 | - | 2.3 | 6.1 | 0.00075 | - | 6.0 |
| 0.55 | 0.75 | 2740 | B-DA71MB | 1.4 | 1.33 | 1.28 | 73.0 | 0.82 | 1.88 | 2.2 | - | 2.3 | 6.1 | 0.0009 | - | 6.5 |
| 0.75 | 1.0 | 2840 | B-DA80MA | 1.9 | 1.8 | 1.74 | 72.1 | 0.83 | 2.52 | 2.3 | - | 2.4 | 6.1 | 0.0012 | 56 | 8.7 |
| 1.1 | 1.5 | 2840 | B-DA80MB | 2.65 | 2.51 | 2.42 | 75.0 | 0.84 | 3.7 | 2.4 | - | 2.4 | 6.3 | 0.0014 | 56 | 9.5 |
| 1.5 | 2.0 | 2840 | B-DA90SA | 3.51 | 3.33 | 3.21 | 77.2 | 0.84 | 5.0 | 2.3 | - | 2.3 | 6.5 | 0.0029 | 61 | 11.8 |
| 2.2 | 3.0 | 2840 | B-DA90LA | 4.93 | 4.68 | 4.51 | 79.7 | 0.85 | 7.4 | 2.4 | - | 2.5 | 6.8 | 0.0055 | 62 | 13.5 |
| 3.0 | 4.0 | 2860 | B-DA100LA | 6.41 | 6.09 | 5.87 | 81.5 | 0.87 | 10.0 | 2.4 | - | 2.4 | 6.9 | 0.0109 | 64 | 21.0 |
| 4.0 | 5.5 | 2880 | B-DA112MA | 8.29 | 7.88 | 7.59 | 83.1 | 0.88 | 13.3 | 2.3 | - | 2.4 | 7.0 | 0.0126 | 65 | 28.0 |
| 5.5 | 7.5 | 2900 | B-DA132SA | 11.2 | 10.6 | 10.3 | 84.7 | 0.88 | 18.1 | 2.2 | - | 2.3 | 7.2 | 0.0377 | 68 | 39.0 |
| 7.5 | 10 | 2900 | B-DA132SB | 15.0 | 14.3 | 13.8 | 86.0 | 0.88 | 24.7 | 2.3 | - | 2.4 | 6.9 | 0.0499 | 68 | 44.5 |
| 11.0 | 15 | 2930 | B-DA160MA | 21.4 | 20.3 | 19.6 | 87.6 | 0.89 | 35.9 | 2.2 | - | 2.3 | 6.8 | 0.055 | 73 | 69.5 |
| 15.0 | 20 | 2930 | B-DA160MB | 28.8 | 27.4 | 26.4 | 88.7 | 0.89 | 48.9 | 2.3 | - | 2.3 | 7.0 | 0.075 | 73 | 78.0 |
| 18.5 | 25 | 2930 | B-DA160LA | 34.9 | 33.2 | 32.0 | 89.3 | 0.90 | 60.3 | 2.4 | - | 2.5 | 7.0 | 0.124 | 73 | 88.5 |
| 22.0 | 30 | 2940 | B-DF180MA | 41.2 | 39.2 | 37.7 | 89.9 | 0.90 | 71.5 | 2.3 | - | 2.3 | 6.9 | 0.075 | 75 | 165 |
| 30.0 | 40 | 2950 | B-DF200LA | 55.8 | 53.0 | 51.1 | 90.7 | 0.90 | 97.1 | 2.2 | - | 2.3 | 7.1 | 0.124 | 78 | 218 |
| 37.0 | 50 | 2950 | B-DF200LB | 68.4 | 65.0 | 62.6 | 91.2 | 0.90 | 119.8 | 2.3 | - | 2.4 | 7.1 | 0.139 | 78 | 230 |
| 45.0 | 60 | 2960 | BU-DF225M | 82.7 | 78.5 | 75.7 | 91.7 | 0.90 | 145.2 | 2.3 | - | 2.5 | 6.8 | 0.233 | 78 | 280 |
| 55.0 | 75 | 2965 | BU-DF250M | 101 | 95.7 | 92.2 | 92.1 | 0.90 | 177.2 | 2.1 | - | 2.2 | 6.8 | 0.312 | 79 | 365 |
| 75.0 | 100 | 2970 | BU-DF280S | 137 | 130 | 125 | 92.7 | 0.90 | 241.2 | 2.3 | - | 2.3 | 7.1 | 0.579 | 80 | 495 |
| 90.0 | 125 | 2970 | BU-DF280MA | 161 | 153 | 147 | 93.0 | 0.91 | 289.4 | 2.2 | - | 2.4 | 7.1 | 0.675 | 80 | 565 |
| 110.0 | 150 | 2975 | BU-DF315SA | 197 | 187 | 180 | 93.3 | 0.91 | 353.1 | 2.2 | - | 2.3 | 7.1 | 1.18 | 82 | 890 |
| 132.0 | 175 | 2975 | BU-DF315MA | 235 | 224 | 216 | 93.5 | 0.91 | 423.7 | 2.3 | - | 2.4 | 6.9 | 1.82 | 82 | 980 |
| 160.0 | 215 | 2975 | BU-DF315LA | 281 | 267 | 258 | 93.8 | 0.92 | 513.6 | 2.2 | - | 2.3 | 7.0 | 2.08 | 85 | 1055 |
| 200.0 | 270 | 2975 | BU-DF315LB | 351 | 333 | 321 | 94.0 | 0.92 | 642 | 2.2 | - | 2.3 | 7.0 | 2.38 | 86 | 1110 |
| 250.0 | 335 | 2980 | BU-DF355M | 438 | 416 | 401 | 94.0 | 0.92 | 801.2 | 2.2 | - | 2.3 | 7.0 | 3.0 | 88 | 1900 |
| 315.0 | 430 | 2980 | BU-DF355L | 552 | 524 | 505 | 94.0 | 0.92 | 1009 | 2.2 | - | 2.3 | 7.0 | 3.5 | 89 | 2300 |
| 355.0 | 475 | 2975 | BU-DF355LB | 618 | 585 | 566 | 95.9 | 0.91 | 1281 | 1.23 | - | 2.53 | 5.80 | 12.52 | - | 2604 |
| 400.0 | 535 | 2975 | BU-DF355LC | 696 | 660 | 637 | 95.9 | 0.91 | 1440 | 1.64 | - | 2.03 | 7.11 | 13.26 | - | 3035 |
| 450.0 | 600 | 2975 | BU-DF355LD | 783 | 741 | 717 | 96.0 | 0.91 | 1681 | 1.47 | - | 2.72 | 6.42 | 14.21 | - | 3122 |
| 500.0 | 670 | 2982 | BU-DF400LA | 853 | 814 | 781 | 96.3 | 0.92 | 1790 | 1.20 | - | 2.90 | 6.14 | 20.07 | - | 3340 |
| 560.0 | 750 | 2982 | BU-DF400LB | 952 | 908 | 871 | 96.3 | 0.92 | 2016 | 0.98 | - | 2.57 | 5.46 | 20.07 | - | 3340 |
| 630.0 | 840 | 2892 | BU-DF400LC | 1072 | 1019 | 981 | 96.3 | 0.93 | 2270 | 1.38 | - | 3.42 | 7.29 | 27.1 | - | 4020 |
| 710.0 | 950 | 2988 | BU-DF450LA | 1195 | 1138 | 1092 | 96.6 | 0.94 | 2269 | 1.20 | - | 2.00 | 7.00 | 27.6 | - | 4200 |
| 800.0 | 1080 | 2986 | BU-DF450LB | 1340 | 1276 | 1227 | 96.7 | 0.94 | 2666 | 1.20 | - | 2.00 | 7.00 | 28.1 | - | 4400 |
| 900.0 | 1200 | 2985 | BU-DF450LC | 1507 | 1435 | 1380 | 96.7 | 0.94 | 2879 | 1.20 | - | 2.00 | 7.00 | 28.1 | - | 4650 |

Performance data

IE1

5

1500 min⁻¹ (4 pole)

Rated power
Full load speed in revolutions per minute
Frame reference and size
Full load current at rated voltage
Efficiency
Power factor
Full load torque
Direct on line starting torque ratio
Direct on line pull up torque
Direct on line pull out torque
Direct on line starting current ratio
Rotor inertia Wkg
Mean sound pressure level (a 1m on no load)
Weight

| P _N | | n min ⁻¹ | Type | I _N | | | h 1.0 P _N | Cos Ø 1.0 P _N | M _N Nm | M _A M _N | M _S M _N | M _K M _N | I _A I _N | J kgm ² | L _{PA} dB(A) | kg |
|----------------|------|------------------------|------------|----------------|------------|------------|-------------------------|-----------------------------|----------------------|----------------------------------|----------------------------------|----------------------------------|----------------------------------|-----------------------|--------------------------|------|
| kW | hp | | | 380 V A | 400 V A | 415 V A | | | | | | | | | | |
| 0.06 | 0.08 | 1325 | B-DA56MA | 0.28 | 0.27 | 0.26 | 56.0 | 0.58 | 0.43 | 2.0 | - | 2.1 | 4.0 | 0.0003 | - | 3.6 |
| 0.09 | 0.12 | 1325 | B-DA56MB | 0.39 | 0.37 | 0.35 | 58.0 | 0.61 | 0.64 | 2.0 | - | 2.1 | 4.0 | 0.0004 | - | 3.9 |
| 0.12 | 0.16 | 1310 | B-DA63MA | 0.44 | 0.42 | 0.41 | 57.0 | 0.72 | 0.84 | 2.1 | - | 2.2 | 4.4 | 0.0005 | - | 4.8 |
| 0.18 | 0.25 | 1310 | B-DA63MB | 0.62 | 0.59 | 0.57 | 60.0 | 0.73 | 1.26 | 2.1 | - | 2.2 | 4.4 | 0.0006 | - | 5.1 |
| 0.25 | 0.33 | 1330 | B-DA71MA | 0.79 | 0.75 | 0.72 | 65.0 | 0.74 | 1.73 | 2.1 | - | 2.2 | 5.2 | 0.0008 | - | 6.0 |
| 0.37 | 0.5 | 1330 | B-DA71MB | 1.12 | 1.06 | 1.02 | 67.0 | 0.75 | 2.56 | 2.1 | - | 2.2 | 5.2 | 0.0013 | - | 6.3 |
| 0.55 | 0.75 | 1390 | B-DA80MA | 1.57 | 1.49 | 1.43 | 71.1 | 0.75 | 3.75 | 2.3 | - | 2.3 | 5.2 | 0.0018 | - | 9.4 |
| 0.75 | 1.0 | 1390 | B-DA80MB | 2.08 | 1.97 | 1.90 | 72.1 | 0.76 | 5.15 | 2.3 | - | 2.3 | 6.1 | 0.0021 | 47 | 10.8 |
| 1.1 | 1.5 | 1390 | B-DA90SA | 2.89 | 2.74 | 2.64 | 75.0 | 0.77 | 7.56 | 2.3 | - | 2.4 | 6.3 | 0.0023 | 49 | 12.0 |
| 1.5 | 2.0 | 1390 | B-DA90LA | 3.73 | 3.55 | 3.42 | 77.2 | 0.79 | 10.3 | 2.4 | - | 2.4 | 6.1 | 0.0027 | 49 | 13.8 |
| 2.2 | 3.0 | 1390 | B-DA100LA | 5.17 | 4.91 | 4.74 | 79.7 | 0.81 | 15.1 | 2.3 | - | 2.4 | 6.5 | 0.0054 | 52 | 20.8 |
| 3.0 | 4.0 | 1410 | B-DA100LB | 6.81 | 6.47 | 6.24 | 81.5 | 0.82 | 20.3 | 2.5 | - | 2.5 | 6.5 | 0.0067 | 52 | 23.5 |
| 4.0 | 5.5 | 1410 | B-DA112MA | 8.91 | 8.46 | 8.16 | 83.1 | 0.82 | 27.1 | 2.4 | - | 2.4 | 7.0 | 0.0095 | 53 | 29.5 |
| 5.5 | 7.5 | 1435 | B-DA132SA | 11.9 | 11.3 | 10.9 | 84.7 | 0.83 | 36.6 | 2.3 | - | 2.4 | 7.0 | 0.0214 | 59 | 41.0 |
| 7.5 | 10 | 1440 | B-DA132MA | 15.7 | 15.0 | 14.4 | 86.0 | 0.84 | 49.7 | 2.3 | - | 2.3 | 7.0 | 0.0296 | 59 | 47.5 |
| 11.0 | 15 | 1440 | B-DA160MA | 22.7 | 21.6 | 20.8 | 87.6 | 0.84 | 72.9 | 2.2 | - | 2.3 | 6.5 | 0.0747 | 62 | 72.5 |
| 15.0 | 20 | 1460 | B-DA160LA | 30.2 | 28.7 | 27.8 | 88.7 | 0.85 | 98.1 | 2.2 | - | 2.2 | 7.2 | 0.0918 | 63 | 85.6 |
| 18.5 | 25 | 1460 | B-DF180MA | 36.4 | 34.5 | 33.3 | 89.3 | 0.86 | 121 | 2.2 | - | 2.3 | 7.5 | 0.139 | 64 | 164 |
| 22.0 | 30 | 1470 | B-DF180LA | 43.1 | 41.0 | 39.5 | 89.9 | 0.86 | 143 | 2.2 | - | 2.3 | 7.2 | 0.158 | 64 | 182 |
| 30.0 | 40 | 1470 | B-DF200L | 58.4 | 55.5 | 53.4 | 90.7 | 0.86 | 195 | 2.3 | - | 2.4 | 7.1 | 0.262 | 66 | 245 |
| 37.0 | 50 | 1470 | B-DF255S | 70.8 | 67.2 | 64.8 | 91.2 | 0.87 | 240 | 2.2 | - | 2.2 | 7.1 | 0.406 | 68 | 258 |
| 45.0 | 60 | 1475 | BU-DF225M | 85.7 | 81.4 | 78.5 | 91.7 | 0.87 | 291 | 2.3 | - | 2.3 | 6.9 | 0.469 | 68 | 290 |
| 55.0 | 75 | 1475 | BU-DF250MA | 104 | 98.9 | 95.3 | 92.1 | 0.87 | 356 | 2.1 | - | 2.2 | 6.8 | 0.66 | 70 | 388 |
| 75.0 | 100 | 1480 | BU-DF280S | 141 | 134 | 129 | 92.7 | 0.87 | 484 | 2.2 | - | 2.2 | 7.5 | 1.12 | 72 | 510 |
| 90.0 | 125 | 1480 | BU-DF280MA | 169 | 160 | 154 | 93.0 | 0.87 | 581 | 2.1 | - | 2.2 | 7.2 | 1.46 | 73 | 606 |
| 110.0 | 150 | 1480 | BU-DF315S | 203 | 193 | 186 | 93.3 | 0.88 | 710 | 2.2 | - | 2.2 | 6.9 | 3.11 | 80 | 910 |
| 132.0 | 175 | 1480 | BU-DF315M | 243 | 231 | 223 | 93.5 | 0.88 | 852 | 2.1 | - | 2.2 | 6.9 | 3.62 | 80 | 1000 |
| 160.0 | 215 | 1480 | BU-DF315LA | 291 | 276 | 266 | 93.8 | 0.89 | 1032 | 2.1 | - | 2.2 | 6.7 | 4.13 | 84 | 1055 |
| 200.0 | 270 | 1480 | BU-DF315LB | 363 | 345 | 332 | 94.0 | 0.89 | 1291 | 2.1 | - | 2.2 | 6.9 | 4.73 | 84 | 1128 |
| 250.0 | 335 | 1490 | BU-DF355M | 449 | 426 | 411 | 94.0 | 0.90 | 1602 | 2.2 | - | 2.2 | 6.9 | 6.5 | 88 | 1700 |
| 315.0 | 430 | 1490 | BU-DF355L | 565 | 537 | 517 | 94.0 | 0.90 | 2019 | 2.1 | - | 2.2 | 6.9 | 8.2 | 88 | 1900 |
| 355.0 | 475 | 1485 | BU-DF355LB | 636 | 604 | 582 | 96.4 | 0.88 | 2283 | 1.93 | - | 2.6 | 6.50 | 9.5 | - | 2150 |
| 400.0 | 535 | 1485 | BU-DF355LC | 716 | 680 | 655 | 96.4 | 0.88 | 2572 | 1.80 | - | 2.6 | 6.50 | 10.6 | - | 2300 |
| 450.0 | 600 | 1485 | BU-DF355LD | 797 | 757 | 729 | 96.4 | 0.89 | 2894 | 1.80 | - | 2.6 | 6.50 | 11.5 | - | 2460 |
| 500.0 | 670 | 1492 | BU-DF400LA | 869 | 831 | 795 | 96.4 | 0.90 | 3203 | 1.83 | - | 2.52 | 6.19 | 18.41 | - | 3132 |
| 560.0 | 750 | 1492 | BU-DF400LB | 971 | 924 | 889 | 96.4 | 0.90 | 3587 | 2.02 | - | 2.67 | 6.64 | 19.62 | - | 3548 |
| 630.0 | 840 | 1492 | BU-DF400LC | 1092 | 1043 | 1000 | 96.4 | 0.91 | 4035 | 1.75 | - | 2.34 | 5.81 | 21.33 | - | 3589 |
| 710.0 | 950 | 1492 | BU-DF450LA | 1222 | 1164 | 1119 | 96.4 | 0.91 | 4530 | 1.30 | - | 2.57 | 6.17 | 41.00 | - | 4055 |
| 800.0 | 1070 | 1492 | BU-DF450LB | 1373 | 1308 | 1257 | 96.6 | 0.93 | 5100 | 1.53 | - | 2.28 | 6.91 | 49.50 | - | 4724 |
| 900.0 | 1200 | 1492 | BU-DF450LC | 1571 | 1496 | 1438 | 96.6 | 0.92 | 5740 | 1.75 | - | 2.34 | 5.81 | 49.50 | - | 4732 |

Performance data

IE1

6

1000 min⁻¹ (6 pole)

Rated power
Full load speed in revolutions per minute
Frame reference and size
Full load current at rated voltage
Efficiency
Power factor
Full load torque
Direct on line starting torque ratio
Direct on line pull up torque
Direct on line pull out torque
Direct on line starting current ratio
Rotor inertia Wkg
Mean sound pressure level (a 1m on no load)
Weight

| P _N | | n min ⁻¹ | Type | I _N | | | h 1.0 P _N | Cos Ø 1.0 P _N | M _N Nm | M _A M _N | M _S M _N | M _K M _N | I _A I _N | J kgm ² | L _{PA} dB(A) | kg |
|----------------|------|------------------------|------------|----------------|------------|------------|-------------------------|-----------------------------|----------------------|----------------------------------|----------------------------------|----------------------------------|----------------------------------|-----------------------|--------------------------|------|
| kW | hp | | | 380 V A | 400 V A | 415 V A | | | | | | | | | | |
| 0.09 | 0.15 | 840 | B-DA63MA | 0.52 | 0.49 | 0.47 | 44.0 | 0.60 | 1.02 | 1.8 | - | 1.9 | 3.5 | 0.00025 | - | 4.8 |
| 0.12 | 0.20 | 850 | B-DA63MB | 0.63 | 0.60 | 0.58 | 48.0 | 0.60 | 1.35 | 1.8 | - | 1.9 | 3.5 | 0.0004 | - | 5.1 |
| 0.18 | 0.25 | 850 | B-DA71MA | 0.74 | 0.70 | 0.68 | 56.0 | 0.66 | 2.02 | 1.9 | - | 2.0 | 4.0 | 0.0011 | - | 6.0 |
| 0.25 | 0.33 | 850 | B-DA71MB | 0.95 | 0.90 | 0.87 | 59.0 | 0.68 | 2.80 | 1.9 | - | 2.0 | 4.0 | 0.0014 | - | 6.3 |
| 0.37 | 0.5 | 885 | B-DA80MA | 1.30 | 1.23 | 1.19 | 62.0 | 0.70 | 3.99 | 1.9 | - | 2.0 | 4.7 | 0.0016 | - | 8.9 |
| 0.55 | 0.75 | 885 | B-DA80MB | 1.78 | 1.69 | 1.63 | 65.0 | 0.72 | 5.94 | 1.9 | - | 2.1 | 4.7 | 0.0019 | - | 10.4 |
| 0.75 | 1.0 | 910 | B-DA90SA | 2.26 | 2.15 | 2.07 | 70.0 | 0.7 | 7.8 | 2.1 | - | 2.1 | 5.5 | 0.0029 | 45 | 12.1 |
| 1.1 | 1.5 | 910 | B-DA90LA | 3.14 | 2.98 | 2.87 | 72.9 | 0.73 | 11.5 | 2.0 | - | 2.1 | 5.5 | 0.0035 | 45 | 13.7 |
| 1.5 | 2.0 | 920 | B-DA100LA | 4.04 | 3.83 | 3.70 | 75.2 | 0.75 | 15.6 | 2.0 | - | 2.0 | 6.0 | 0.0069 | 49 | 23.0 |
| 2.2 | 3.0 | 935 | B-DA112MA | 5.65 | 5.36 | 5.17 | 77.7 | 0.76 | 22.5 | 2.2 | - | 2.2 | 6.0 | 0.014 | 53 | 28.2 |
| 3.0 | 4.0 | 960 | B-DA132SA | 7.52 | 7.14 | 6.88 | 79.7 | 0.76 | 29.8 | 2.0 | - | 2.1 | 6.5 | 0.0286 | 57 | 40.3 |
| 4.0 | 5.5 | 960 | B-DA132MA | 9.80 | 9.31 | 8.97 | 81.4 | 0.76 | 39.8 | 2.0 | - | 2.1 | 6.5 | 0.0357 | 57 | 43.0 |
| 5.5 | 7.5 | 960 | B-DA132MB | 13.1 | 12.4 | 12.0 | 83.1 | 0.77 | 54.7 | 2.2 | - | 2.2 | 6.5 | 0.0449 | 57 | 47.2 |
| 7.5 | 10 | 970 | B-DA160MA | 17.4 | 16.6 | 16.0 | 84.7 | 0.77 | 73.8 | 2.0 | - | 2.1 | 6.7 | 0.081 | 61 | 70.6 |
| 11.0 | 15 | 970 | B-DA160LA | 22.2 | 21.1 | 20.3 | 86.4 | 0.78 | 108.3 | 2.2 | - | 2.3 | 6.7 | 0.116 | 61 | 85.0 |
| 15.0 | 20 | 970 | B-DF180LA | 32.0 | 30.4 | 29.3 | 87.7 | 0.81 | 147.7 | 2.1 | - | 2.2 | 6.7 | 0.207 | 61 | 178 |
| 18.5 | 25 | 980 | B-DF200LA | 39.1 | 37.2 | 35.8 | 88.6 | 0.81 | 180.3 | 2.2 | - | 2.2 | 6.7 | 0.315 | 64 | 200 |
| 22.0 | 30 | 980 | B-DF200LB | 45.1 | 42.8 | 41.3 | 89.2 | 0.83 | 214.4 | 2.1 | - | 2.2 | 6.7 | 0.36 | 64 | 228 |
| 30.0 | 40 | 980 | BU-DF225M | 60.1 | 57.1 | 55.0 | 90.2 | 0.84 | 292.3 | 2.1 | - | 2.1 | 7.0 | 0.547 | 64 | 265 |
| 37.0 | 50 | 980 | BU-DF250M | 71.9 | 68.3 | 65.8 | 90.8 | 0.86 | 360.6 | 2.1 | - | 2.2 | 7.0 | 0.843 | 66 | 370 |
| 45.0 | 60 | 980 | BU-DF280S | 86.8 | 82.5 | 79.5 | 91.4 | 0.86 | 438.5 | 2.0 | - | 2.1 | 7.0 | 1.39 | 68 | 490 |
| 55.0 | 75 | 980 | BU-DF280MA | 106 | 100 | 96.7 | 91.9 | 0.86 | 536 | 2.1 | - | 2.2 | 7.0 | 1.65 | 68 | 540 |
| 75.0 | 100 | 985 | BU-DF315SA | 143 | 136 | 131 | 92.6 | 0.86 | 727 | 2.1 | - | 2.2 | 7.0 | 4.11 | 73 | 900 |
| 90.0 | 125 | 985 | BU-DF315MA | 171 | 162 | 156 | 92.9 | 0.86 | 873 | 2.0 | - | 2.1 | 6.7 | 4.78 | 73 | 980 |
| 110.0 | 150 | 985 | BU-DF315LA | 208 | 197 | 190 | 93.3 | 0.86 | 1066 | 2.0 | - | 2.1 | 6.7 | 5.45 | 73 | 1045 |
| 132.0 | 175 | 985 | BU-DF315LB | 246 | 234 | 226 | 93.5 | 0.87 | 1280 | 2.0 | - | 2.1 | 6.7 | 6.12 | 73 | 1100 |
| 160.0 | 215 | 985 | BU-DF355MA | 295 | 280 | 270 | 93.8 | 0.88 | 1551 | 1.9 | - | 2.0 | 6.7 | 9.5 | 80 | 1550 |
| 200.0 | 270 | 985 | BU-DF355MB | 367 | 349 | 336 | 94.0 | 0.88 | 1939 | 1.9 | - | 2.0 | 6.7 | 10.4 | 80 | 1600 |
| 250.0 | 335 | 985 | BU-DF355L | 459 | 436 | 420 | 94.0 | 0.88 | 2424 | 1.9 | - | 2.0 | 6.7 | 12.4 | 80 | 1700 |
| 315.0 | 420 | 990 | BU-DA355LA | 590 | 557 | 540 | 95.5 | 0.85 | 3039 | 2.10 | - | 2.40 | 6.50 | 13.5 | - | 2310 |
| 355.0 | 480 | 990 | BU-DF355LB | 663 | 628 | 607 | 95.7 | 0.85 | 3425 | 2.10 | - | 2.40 | 6.50 | 14.3 | - | 2490 |
| 400.0 | 544 | 990 | BU-DF400LA | 730 | 701 | 668 | 95.9 | 0.86 | 3843 | 2.08 | - | 2.48 | 6.38 | 21.86 | - | 3560 |
| 450.0 | 612 | 994 | BU-DF400LB | 819 | 783 | 750 | 95.9 | 0.86 | 4323 | 2.07 | - | 2.43 | 6.31 | 22.31 | - | 3840 |
| 500.0 | 680 | 994 | BU-DF400LC | 908 | 871 | 831 | 96.1 | 0.86 | 4804 | 1.86 | - | 2.19 | 5.72 | 23.52 | - | 3870 |
| 560.0 | 760 | 994 | BU-DF450MB | 918 | 874 | 840 | 96.0 | 0.86 | 4785 | 1.64 | - | 2.32 | 5.99 | 54.10 | - | 4200 |
| 630.0 | 850 | 994 | BU-DF450LA | 1152 | 1097 | 1055 | 96.1 | 0.86 | 6025 | 1.65 | - | 2.30 | 5.99 | 60.60 | - | 4620 |
| 710.0 | 960 | 994 | BU-DF450LB | 1297 | 1235 | 1187 | 95.9 | 0.86 | 6790 | 1.71 | - | 2.33 | 6.13 | 67.90 | - | 5080 |
| 800.0 | 1080 | 994 | BU-DF450LC | 1450 | 1381 | 1327 | 96.5 | 0.87 | 7680 | 1.52 | - | 2.06 | 5.47 | 67.90 | - | 5080 |

Performance data

750 min⁻¹ (8 pole)

7

| Rated power | | Full load speed in revolutions per minute | Frame reference and size | Full load current at rated voltage | | | Efficiency | Power factor | Full load torque | Direct on line starting torque ratio | Direct on line pull up torque | Direct on line pull out torque | Direct on line starting current ratio | Rotor inertia W/Kg | Mean sound pressure level @ 1m on no load | Weight |
|----------------|------|---|--------------------------|------------------------------------|---------|---------|---------------------|------------------------------------|-------------------|--------------------------------------|-------------------------------|--------------------------------|---------------------------------------|--------------------|---|--------|
| P _N | | | | I _N | | | | | | | | | | | | |
| kW | hp | n min ⁻¹ | Type | 380 V A | 400 V A | 415 V A | $\frac{h}{1.0 P_N}$ | Cos \emptyset 1.0 P _N | M _N Nm | $\frac{M_A}{M_N}$ | $\frac{M_S}{M_N}$ | $\frac{M_K}{M_N}$ | $\frac{I_A}{I_N}$ | J kgm ² | L _{PA} dB(A) | kg |
| 0.09 | 0.15 | 600 | B-DA71MA | 0.60 | 0.57 | 0.55 | 40.0 | 0.57 | 1.3 | 1.8 | - | 1.9 | 2.8 | 0.0008 | 48 | 6.0 |
| 0.12 | 0.20 | 600 | B-DA71MB | 0.71 | 0.70 | 0.65 | 45.0 | 0.57 | 2.16 | 1.8 | - | 1.9 | 2.8 | 0.0010 | 48 | 6.3 |
| 0.18 | 0.25 | 645 | B-DA80MA | 0.88 | 0.84 | 0.80 | 51.0 | 0.61 | 2.5 | 1.8 | - | 1.9 | 3.3 | 0.0025 | 48 | 8.9 |
| 0.25 | 0.33 | 645 | B-DA80MB | 1.15 | 1.10 | 1.06 | 54.0 | 0.61 | 3.5 | 1.8 | - | 1.9 | 3.0 | 0.0030 | 48 | 10.4 |
| 0.37 | 0.5 | 670 | B-DA90S | 1.49 | 1.41 | 1.4 | 62.0 | 0.61 | 5.1 | 1.8 | - | 1.9 | 4.0 | 0.0051 | 53 | 12.1 |
| 0.55 | 0.75 | 670 | B-DA90LA | 2.17 | 2.07 | 1.99 | 63.0 | 0.61 | 7.6 | 1.8 | - | 2.0 | 4.0 | 0.0065 | 53 | 13.7 |
| 0.75 | 1.0 | 680 | B-DA100LA | 2.40 | 2.28 | 2.2 | 71.0 | 0.67 | 10.2 | 1.8 | - | 2.0 | 4.0 | 0.0095 | 56 | 23.0 |
| 1.1 | 1.5 | 680 | B-DA100LB | 3.32 | 3.15 | 3.04 | 73.0 | 0.69 | 15.0 | 1.8 | - | 2.0 | 5.0 | 0.0110 | 56 | 25.1 |
| 1.5 | 2.0 | 690 | B-DA112MA | 4.40 | 4.18 | 4.0 | 75.0 | 0.69 | 20.5 | 1.8 | - | 2.0 | 5.0 | 0.0245 | 59 | 28.2 |
| 2.2 | 3.0 | 705 | B-DA132S | 6.04 | 5.73 | 5.5 | 78.0 | 0.71 | 19.6 | 1.8 | - | 2.0 | 6.0 | 0.0314 | 61 | 40.3 |
| 3.0 | 4.0 | 705 | B-DA132M | 7.9 | 7.51 | 7.2 | 79.0 | 0.73 | 40.4 | 1.8 | - | 2.0 | 6.0 | 0.0395 | 61 | 45.0 |
| 4.0 | 5.5 | 720 | B-DA160MA | 10.3 | 9.76 | 9.4 | 81.0 | 0.73 | 53.1 | 1.9 | - | 2.0 | 6.0 | 0.0753 | 65 | 68.5 |
| 5.5 | 7.5 | 720 | B-DA160MB | 13.6 | 12.9 | 12.5 | 83.0 | 0.74 | 72.6 | 2.0 | - | 2.0 | 6.0 | 0.0931 | 65 | 76.0 |
| 7.5 | 10 | 720 | B-DA160L | 17.8 | 16.9 | 16.3 | 85.5 | 0.75 | 99.5 | 2.0 | - | 2.0 | 6.0 | 0.1260 | 65 | 86.2 |
| 11.0 | 15 | 730 | B-DF180L | 25.1 | 23.9 | 23 | 87.5 | 0.76 | 143.9 | 2.0 | - | 2.0 | 6.0 | 0.203 | 70 | 160 |
| 15.0 | 20 | 730 | B-DF200L | 34.1 | 32.4 | 31.2 | 88.0 | 0.76 | 196.2 | 2.0 | - | 2.0 | 6.6 | 0.399 | 73 | 228 |
| 18.5 | 25 | 730 | BU-DF225S | 41.1 | 39 | 37.6 | 90.0 | 0.76 | 242.0 | 1.9 | - | 2.0 | 6.6 | 0.491 | 73 | 242 |
| 22.0 | 30 | 730 | BU-DF225M | 47.4 | 45 | 43.4 | 90.5 | 0.78 | 287.8 | 1.9 | - | 2.0 | 6.6 | 0.547 | 73 | 265 |
| 30.0 | 40 | 735 | BU-DF250M | 63.4 | 60.2 | 58.1 | 91.0 | 0.79 | 382.5 | 1.9 | - | 2.0 | 6.6 | 0.834 | 75 | 368 |
| 37.0 | 50 | 735 | BU-DF280S | 77.8 | 73.9 | 71.2 | 91.5 | 0.79 | 484.0 | 1.9 | - | 2.0 | 6.6 | 1.93 | 76 | 472 |
| 45.0 | 60 | 735 | BU-DF280M | 94.1 | 89.4 | 86.1 | 92.0 | 0.79 | 580.7 | 1.8 | - | 2.0 | 6.6 | 3.65 | 76 | 538 |
| 55.0 | 75 | 735 | BU-DF315SA | 111 | 106 | 102 | 92.8 | 0.81 | 709.8 | 1.8 | - | 2.0 | 6.6 | 4.79 | 82 | 900 |
| 75.0 | 100 | 735 | BU-DF315MA | 151 | 144 | 139 | 93.0 | 0.81 | 967.9 | 1.8 | - | 2.0 | 6.6 | 5.58 | 82 | 1000 |
| 90.0 | 125 | 735 | BU-DF315LA | 178 | 169 | 163 | 93.8 | 0.82 | 1161.5 | 1.8 | - | 2.0 | 6.6 | 6.37 | 82 | 1055 |
| 110.0 | 150 | 735 | BU-DF315LB | 217 | 206 | 199 | 94.0 | 0.82 | 1419.6 | 1.8 | - | 2.0 | 6.4 | 7.23 | 82 | 1118 |
| 132.0 | 175 | 740 | BU-DF355MA | 261 | 248 | 239 | 93.7 | 0.82 | 1692.1 | 1.8 | - | 2.0 | 6.4 | 7.9 | 90 | 2000 |
| 160.0 | 215 | 740 | BU-DF355MB | 315 | 299 | 288 | 94.2 | 0.82 | 2051.0 | 1.8 | - | 2.0 | 6.4 | 10.3 | 90 | 2150 |
| 200.0 | 270 | 740 | BU-DF355L | 387 | 368 | 355 | 94.5 | 0.83 | 2563.4 | 1.8 | - | 2.0 | 6.4 | 12.3 | 90 | 2250 |
| 250.0 | 340 | 740 | BU-DF355LB | 511 | 485 | 468 | 95.3 | 0.78 | 3226 | 1.80 | - | 2.0 | 6.5 | 14.53 | - | 2460 |
| 315.0 | 420 | 740 | BU-DF355LC | 642 | 610 | 588 | 95.5 | 0.78 | 4065 | 1.80 | - | 2.0 | 6.5 | 15.39 | - | 2750 |
| 355.0 | 480 | 745 | BU-DF400LB | 667 | 641 | 610 | 95.6 | 0.85 | 4557 | 1.72 | - | 2.25 | 5.84 | 29.76 | - | 3592 |
| 400.0 | 540 | 745 | BU-DF400LC | 750 | 723 | 687 | 95.6 | 0.85 | 5128 | 1.96 | - | 2.44 | 6.39 | 31.34 | - | 3949 |
| 450.0 | 600 | 745 | BU-DF450LB | 858 | 817 | 785 | 95.7 | 0.83 | 5740 | 1.62 | - | 2.18 | 5.43 | 75.20 | - | 4660 |
| 500.0 | 675 | 745 | BU-DF450LC | 959 | 913 | 878 | 95.7 | 0.83 | 6675 | 1.74 | - | 2.23 | 5.65 | 79.30 | - | 4870 |

Performance data

IE2

8

3000 min⁻¹ (2 pole)

Rated power
Full load speed in revolutions per minute
Frame reference and size
Full load current at rated voltage
Efficiency
Power factor
Full load torque
Direct on line starting torque ratio
Direct on line pull up torque
Direct on line pull out torque
Direct on line starting current ratio
Rotor inertia W/Kg
Mean Sound pressure level (a 1m on no load)
Weight

| P _N | | n min ⁻¹ | Type | I _N | | | h 1.0 P _N | Cos Ø 1.0 P _N | M _N Nm | M _A M _N | M _S M _N | M _K M _N | I _A I _N | J kgm ² | L _{PA} dB(A) | kg |
|----------------|-----|------------------------|------------|----------------|------------|------------|-------------------------|-----------------------------|----------------------|----------------------------------|----------------------------------|----------------------------------|----------------------------------|-----------------------|--------------------------|------|
| kW | hp | | | 380 V A | 400 V A | 415 V A | | | | | | | | | | |
| 0.75 | 1.0 | 2875 | A-DA80MA | 1.77 | 1.68 | 1.62 | 77.4 | 0.83 | 2.49 | 2.5 | - | 3.0 | 5.3 | 0.0012 | 56 | 12.0 |
| 1.1 | 1.5 | 2875 | A-DA80MB | 2.50 | 2.37 | 2.29 | 79.6 | 0.84 | 3.65 | 3.2 | - | 3.8 | 7.0 | 0.0014 | 57 | 13.5 |
| 1.5 | 2.0 | 2890 | A-DA90SA | 3.32 | 3.16 | 3.04 | 81.3 | 0.84 | 4.96 | 2.7 | - | 3.5 | 7.1 | 0.0029 | 61 | 17.5 |
| 2.2 | 3.0 | 2890 | A-DA90LA | 4.72 | 4.48 | 4.32 | 83.2 | 0.85 | 7.27 | 2.4 | - | 3.0 | 6.9 | 0.0055 | 61 | 22.0 |
| 3.0 | 4.0 | 2890 | A-DA100LA | 6.17 | 5.86 | 5.65 | 84.6 | 0.87 | 9.91 | 3.2 | - | 4.0 | 8.0 | 0.0109 | 63 | 29.0 |
| 4.0 | 5.5 | 2900 | A-DA112MA | 8.04 | 7.64 | 7.36 | 85.8 | 0.88 | 13.1 | 2.5 | - | 3.0 | 7.5 | 0.0126 | 65 | 32.0 |
| 5.5 | 7.5 | 2930 | A-DA132SA | 11.2 | 10.6 | 10.2 | 87.0 | 0.86 | 17.9 | 2.7 | - | 3.5 | 7.5 | 0.0377 | 68 | 47.5 |
| 7.5 | 10 | 2940 | A-DA132SB | 14.6 | 13.9 | 13.4 | 88.1 | 0.88 | 24.4 | 2.4 | - | 3.3 | 7.5 | 0.0499 | 68 | 53.0 |
| 11.0 | 15 | 2930 | A-DA160MA | 21.0 | 19.9 | 19.2 | 89.4 | 0.89 | 35.9 | 2.2 | - | 2.9 | 7.6 | 0.055 | 72 | 96.0 |
| 15.0 | 20 | 2930 | A-DA160MB | 28.4 | 26.9 | 26.0 | 90.3 | 0.89 | 48.9 | 2.3 | - | 3.0 | 7.6 | 0.075 | 73 | 105 |
| 18.5 | 25 | 2940 | A-DA160LA | 34.7 | 33.0 | 31.8 | 90.9 | 0.89 | 60.2 | 2.3 | - | 3.1 | 7.4 | 0.124 | 73 | 115 |
| 22.0 | 30 | 2940 | A-DF180MA | 41.6 | 39.5 | 38.1 | 91.3 | 0.88 | 71.5 | 2.8 | - | 3.2 | 7.8 | 0.075 | 74 | 187 |
| 30.0 | 40 | 2950 | A-DF200LA | 56.2 | 53.4 | 51.5 | 92.0 | 0.88 | 97.1 | 2.6 | - | 3.0 | 7.8 | 0.124 | 77 | 241 |
| 37.0 | 50 | 2950 | A-DF200LB | 68.2 | 64.8 | 62.5 | 92.5 | 0.89 | 119.8 | 2.6 | - | 3.0 | 7.7 | 0.139 | 77 | 261 |
| 45.0 | 60 | 2960 | AU-DF225M | 82.5 | 78.4 | 75.6 | 92.9 | 0.89 | 145.2 | 2.4 | - | 2.6 | 7.5 | 0.233 | 77 | 348 |
| 55.0 | 75 | 2965 | AU-DF250M | 99.5 | 94.5 | 91.1 | 93.2 | 0.90 | 177.2 | 2.3 | - | 2.8 | 7.1 | 0.312 | 80 | 400 |
| 75.0 | 100 | 2970 | AU-DF280S | 135 | 128 | 123 | 93.8 | 0.90 | 241.2 | 2.5 | - | 2.8 | 7.4 | 0.579 | 80 | 540 |
| 90.0 | 125 | 2970 | AU-DF280MA | 160 | 152 | 146 | 94.1 | 0.91 | 289.4 | 2.8 | - | 2.8 | 7.6 | 0.675 | 80 | 588 |
| 110.0 | 150 | 2975 | AU-DF315SA | 194 | 185 | 178 | 94.3 | 0.91 | 353.1 | 2.4 | - | 2.8 | 6.9 | 1.18 | 81 | 948 |
| 132.0 | 175 | 2975 | AU-DF315MA | 233 | 221 | 213 | 94.6 | 0.91 | 423.7 | 2.6 | - | 2.9 | 7.1 | 1.82 | 81 | 1009 |
| 160.0 | 215 | 2975 | AU-DF315LA | 278 | 265 | 255 | 94.8 | 0.92 | 513.6 | 2.5 | - | 2.9 | 7.1 | 2.08 | 85 | 1111 |
| 200.0 | 270 | 2975 | AU-DF315LB | 348 | 330 | 318 | 95.0 | 0.92 | 642 | 2.5 | - | 2.8 | 6.9 | 2.38 | 85 | 1142 |
| 250.0 | 335 | 2980 | AU-DF355M | 434 | 412 | 398 | 95.0 | 0.92 | 801.2 | 2.5 | - | 2.8 | 7.0 | 3.0 | 88 | 1938 |
| 315.0 | 430 | 2980 | AU-DF355L | 547 | 520 | 501 | 95.0 | 0.92 | 1009 | 2.5 | - | 2.9 | 7.0 | 3.5 | 88 | 2346 |

IE2 efficiency 0.75 to 375kW

Performance data

IE2

9

1500 min⁻¹ (4 pole)

| P _N | | n min ⁻¹ | Type | I _N | | | h 1.0 P _N | Cos φ 1.0 P _N | M _N Nm | M _A M _N | M _S M _N | M _K M _N | I _A I _N | J kgm ² | L _{PA} dB(A) | kg |
|----------------|-----|------------------------|------------|----------------|------------|------------|-------------------------|-----------------------------|----------------------|----------------------------------|----------------------------------|----------------------------------|----------------------------------|-----------------------|--------------------------|------|
| kW | hp | | | 380 V A | 400 V A | 415 V A | | | | | | | | | | |
| 0.75 | 1.0 | 1400 | A-DA80MB | 1.88 | 1.78 | 1.72 | 79.6 | 0.76 | 5.12 | 2.4 | - | 2.9 | 5.0 | 0.0021 | 46 | 14.5 |
| 1.1 | 1.5 | 1440 | A-DA90SA | 2.66 | 2.53 | 2.44 | 81.4 | 0.77 | 7.3 | 3.0 | - | 3.5 | 6.0 | 0.0023 | 48 | 18.5 |
| 1.5 | 2.0 | 1445 | A-DA90LA | 3.57 | 3.39 | 3.27 | 82.8 | 0.77 | 9.9 | 3.2 | - | 3.8 | 6.8 | 0.0027 | 48 | 21.0 |
| 2.2 | 3.0 | 1440 | A-DA100LA | 4.88 | 4.64 | 4.47 | 84.3 | 0.81 | 14.6 | 3.0 | - | 3.5 | 7.0 | 0.0054 | 52 | 31.0 |
| 3.0 | 4.0 | 1440 | A-DA100LB | 6.50 | 6.18 | 5.95 | 85.5 | 0.82 | 19.9 | 2.6 | - | 3.3 | 7.0 | 0.0067 | 52 | 37.0 |
| 4.0 | 5.5 | 1445 | A-DA112MA | 8.55 | 8.12 | 7.83 | 86.6 | 0.82 | 26.4 | 3.5 | - | 4.0 | 7.5 | 0.0095 | 53 | 42.0 |
| 5.5 | 7.5 | 1455 | A-DA132SA | 11.5 | 10.9 | 10.5 | 87.7 | 0.83 | 36.1 | 2.2 | - | 2.8 | 6.4 | 0.0214 | 59 | 52.5 |
| 7.5 | 10 | 1455 | A-DA132MA | 15.3 | 14.5 | 14.0 | 88.7 | 0.84 | 49.2 | 2.4 | - | 3.0 | 7.0 | 0.0296 | 59 | 64.0 |
| 11.0 | 15 | 1460 | A-DA160MA | 22.1 | 21.0 | 20.3 | 89.8 | 0.84 | 71.9 | 2.5 | - | 2.9 | 6.9 | 0.0747 | 62 | 99.0 |
| 15.0 | 20 | 1460 | A-DA160LA | 29.6 | 28.1 | 27.1 | 90.6 | 0.85 | 98.1 | 2.5 | - | 3.0 | 7.5 | 0.0918 | 62 | 114 |
| 18.5 | 25 | 1470 | A-DF180MA | 35.8 | 34.0 | 32.8 | 91.2 | 0.86 | 120 | 2.6 | - | 3.1 | 7.8 | 0.139 | 64 | 185 |
| 22.0 | 30 | 1470 | A-DF180LA | 42.3 | 40.2 | 38.8 | 91.6 | 0.86 | 143 | 2.6 | - | 3.1 | 7.5 | 0.158 | 64 | 200 |
| 30.0 | 40 | 1470 | A-DF200L | 57.3 | 54.4 | 52.5 | 92.3 | 0.86 | 195 | 2.4 | - | 2.9 | 7.1 | 0.262 | 64 | 270 |
| 37.0 | 50 | 1480 | A-DF255S | 69.7 | 66.2 | 63.8 | 92.7 | 0.87 | 239 | 2.5 | - | 2.7 | 7.5 | 0.406 | 64 | 310 |
| 45.0 | 60 | 1480 | AU-DF225M | 84.3 | 80.1 | 77.2 | 93.1 | 0.87 | 291 | 2.5 | - | 2.8 | 7.6 | 0.469 | 65 | 340 |
| 55.0 | 75 | 1480 | AU-DF250MA | 103 | 97.5 | 94.0 | 93.5 | 0.87 | 355 | 2.6 | - | 2.7 | 7.3 | 0.66 | 66 | 413 |
| 75.0 | 100 | 1480 | AU-DF280S | 139 | 132 | 127 | 94.0 | 0.87 | 484 | 2.7 | - | 2.7 | 7.6 | 1.12 | 69 | 530 |
| 90.0 | 125 | 1480 | AU-DF280MA | 167 | 158 | 153 | 94.2 | 0.87 | 581 | 2.7 | - | 2.7 | 7.5 | 1.46 | 69 | 630 |
| 110.0 | 150 | 1485 | AU-DF315S | 201 | 191 | 184 | 94.5 | 0.88 | 707 | 2.7 | - | 2.9 | 7.1 | 3.11 | 77 | 950 |
| 132.0 | 175 | 1485 | AU-DF315M | 240 | 228 | 220 | 94.7 | 0.88 | 849 | 2.7 | - | 2.9 | 7.3 | 3.62 | 77 | 1037 |
| 160.0 | 215 | 1485 | AU-DF315LA | 288 | 273 | 263 | 94.9 | 0.89 | 1029 | 3.0 | - | 3.0 | 7.4 | 4.13 | 82 | 1107 |
| 200.0 | 270 | 1485 | AU-DF315LB | 359 | 341 | 328 | 95.1 | 0.89 | 1286 | 3.0 | - | 3.0 | 7.6 | 4.73 | 82 | 1225 |
| 250.0 | 335 | 1490 | AU-DF355M | 443 | 421 | 406 | 95.1 | 0.90 | 1602 | 2.8 | - | 2.9 | 7.5 | 6.5 | 84 | 1734 |
| 315.0 | 430 | 1490 | AU-DF355L | 559 | 531 | 511 | 95.1 | 0.90 | 2019 | 2.6 | - | 2.8 | 7.4 | 8.2 | 84 | 1940 |

IE2 efficiency 0.75 to 375kW

Performance data

IE2

10

1000 min⁻¹ (6 pole)

Rated power
Full load speed in revolutions per minute
Frame reference and size
Full load current at rated voltage
Efficiency
Power factor
Full load torque
Direct on line starting torque ratio
Direct on line pull up torque
Direct on line pull out torque
Direct on line starting current ratio
Rotor inertia Wk²
Mean Sound pressure level @ 1m on no load
Weight

| P _N | | n min ⁻¹ | Type | I _N | | | h 1.0 P _N | Cos Ø 1.0 P _N | M _N Nm | M _A M _N | M _S M _N | M _K M _N | I _A I _N | J kgm ² | L _{PA} dB(A) | kg |
|----------------|-----|------------------------|------------|----------------|------------|------------|-------------------------|-----------------------------|----------------------|----------------------------------|----------------------------------|----------------------------------|----------------------------------|-----------------------|--------------------------|------|
| kW | hp | | | 380 V A | 400 V A | 415 V A | | | | | | | | | | |
| 0.75 | 1.0 | 935 | A-DA90SA | 2.08 | 1.98 | 1.90 | 75.9 | 0.72 | 7.67 | 2.2 | - | 2.4 | 4.5 | 0.0029 | 45 | 18.5 |
| 1.1 | 1.5 | 945 | A-DA90LA | 2.97 | 2.82 | 2.72 | 78.1 | 0.72 | 11.1 | 2.4 | - | 2.6 | 4.5 | 0.0035 | 45 | 21.0 |
| 1.5 | 2.0 | 945 | A-DA100LA | 3.80 | 3.61 | 3.48 | 79.8 | 0.75 | 15.2 | 1.8 | - | 2.2 | 4.2 | 0.0069 | 49 | 28.5 |
| 2.2 | 3.0 | 960 | A-DA112MA | 5.37 | 5.10 | 4.92 | 81.8 | 0.76 | 21.9 | 2.3 | - | 2.8 | 4.5 | 0.014 | 53 | 33.5 |
| 3.0 | 4.0 | 965 | A-DA132SA | 7.19 | 6.83 | 6.58 | 83.3 | 0.76 | 29.7 | 1.8 | - | 2.4 | 4.5 | 0.0286 | 53 | 44.0 |
| 4.0 | 5.5 | 965 | A-DA132MA | 9.43 | 8.96 | 8.63 | 84.6 | 0.76 | 39.6 | 2.3 | - | 2.7 | 5.0 | 0.0357 | 55 | 53.0 |
| 5.5 | 7.5 | 965 | A-DA132MB | 12.6 | 12.0 | 11.5 | 86.0 | 0.77 | 54.4 | 1.9 | - | 2.8 | 5.5 | 0.0449 | 55 | 63.5 |
| 7.5 | 10 | 970 | A-DA160MA | 16.7 | 15.9 | 15.3 | 87.2 | 0.78 | 73.8 | 2.0 | - | 3.0 | 6.5 | 0.081 | 57 | 100 |
| 11.0 | 15 | 970 | A-DA160LA | 24.1 | 22.9 | 22.1 | 88.7 | 0.78 | 108.3 | 2.4 | - | 3.3 | 7.5 | 0.116 | 57 | 113 |
| 15.0 | 20 | 975 | A-DF180LA | 31.4 | 29.8 | 28.7 | 89.7 | 0.81 | 147 | 2.0 | - | 2.7 | 6.4 | 0.207 | 58 | 198 |
| 18.5 | 25 | 980 | A-DF200LA | 38.3 | 36.4 | 35.1 | 90.4 | 0.81 | 180 | 2.3 | - | 3.0 | 7.0 | 0.315 | 58 | 236 |
| 22.0 | 30 | 980 | A-DF200LB | 44.3 | 42.0 | 40.5 | 90.9 | 0.83 | 214 | 2.3 | - | 2.8 | 7.0 | 0.36 | 61 | 251 |
| 30.0 | 40 | 980 | AU-DF225M | 59.2 | 56.2 | 54.2 | 91.7 | 0.84 | 292 | 2.2 | - | 2.7 | 6.5 | 0.547 | 62 | 317 |
| 37.0 | 50 | 980 | AU-DF250M | 70.8 | 67.3 | 64.8 | 92.2 | 0.86 | 361 | 2.5 | - | 2.7 | 6.9 | 0.843 | 62 | 397 |
| 45.0 | 60 | 980 | AU-DF280S | 85.8 | 81.5 | 78.5 | 92.7 | 0.86 | 439 | 2.2 | - | 2.4 | 7.0 | 1.39 | 63 | 513 |
| 55.0 | 75 | 980 | AU-DF280MA | 104 | 99.2 | 95.6 | 93.1 | 0.86 | 536 | 2.4 | - | 2.5 | 7.1 | 1.65 | 64 | 562 |
| 75.0 | 100 | 985 | AU-DF315SA | 141 | 134 | 129 | 93.7 | 0.86 | 727 | 2.8 | - | 3.0 | 7.3 | 4.11 | 68 | 933 |
| 90.0 | 125 | 985 | AU-DF315MA | 169 | 160 | 155 | 94.0 | 0.86 | 873 | 2.7 | - | 2.9 | 7.1 | 4.78 | 68 | 1013 |
| 110.0 | 150 | 985 | AU-DF315LA | 206 | 196 | 189 | 94.3 | 0.86 | 1066 | 2.9 | - | 2.9 | 7.4 | 5.45 | 73 | 1086 |
| 132.0 | 175 | 985 | AU-DF315LB | 243 | 231 | 223 | 94.6 | 0.87 | 1280 | 3.0 | - | 3.1 | 7.6 | 6.12 | 73 | 1208 |
| 160.0 | 215 | 990 | AU-DF355MA | 291 | 277 | 267 | 94.8 | 0.88 | 1543 | 3.1 | - | 3.1 | 7.6 | 9.5 | 78 | 1581 |
| 200.0 | 270 | 990 | AU-DF355MB | 363 | 345 | 333 | 95.0 | 0.88 | 1929 | 3.0 | - | 3.0 | 7.8 | 10.4 | 78 | 1632 |
| 250.0 | 335 | 990 | AU-DF355L | 454 | 432 | 416 | 95.0 | 0.88 | 2412 | 3.1 | - | 3.0 | 7.7 | 12.4 | 78 | 1734 |

IE2 efficiency 0.75 to 375kW

Performance data notes

Speed / torque & speed / current curves

DOL starting

Typical speed/current curve

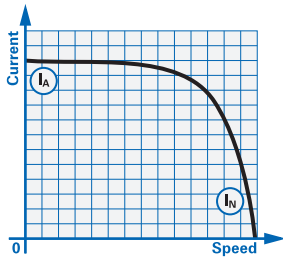

Typical speed/torque curve

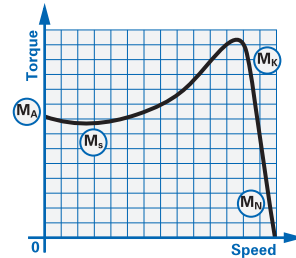

- (I_A) Starting current
- (I_N) Full load current
- (M_A) Starting torque or locked rotor torque
- (M_S) Pull up torque or run up torque
- (M_K) Pull out torque or breakdown torque
- (M_N) Full load torque

Torque/speed curves for specific motors can be supplied on request.

During the run up period in Star, there must be an adequate excess of motor torque over the load torque. The change to Delta must not occur until the motor is near the operating speed. Refer to Brook Crompton for running up against a load in excess of 70% full load during Star Delta starting.

Performance figures are subject to IEC tolerances. Performance figures are based on a 400 volt winding.

$$J \text{ (WK}^2 \text{ or WR}^2) = \frac{GD^2}{4}$$

$$J \text{ in lb ft}^2 = \frac{\text{kgm}^2}{0.042}$$

Connection diagrams

| Star Delta | Dual voltage | Thermistors - (PTC) | Thermostats - (PTO) |
|-------------------------|--------------|--|---|
| <p>Motors => 4kW</p> | | <p>Connect to thermistor control unit.</p> | <p>Connect to overload protection circuit</p> |

Dimensions

IE1

12

Foot, flange and face mounting - frame sizes 56 to 160 aluminium

IM B3
IM 1001
Mounting options

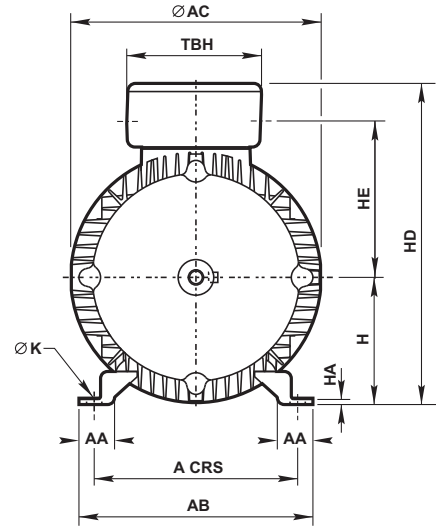
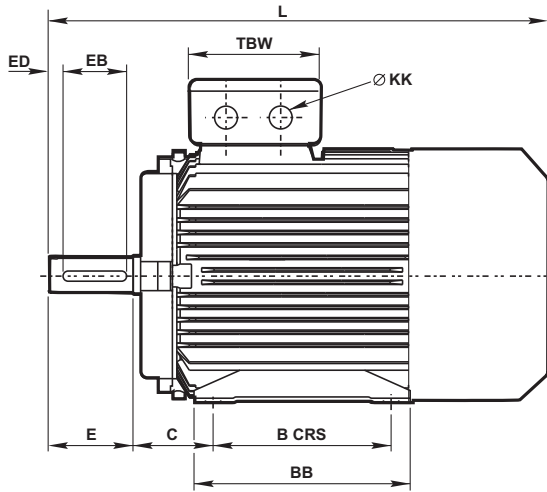

IM B5/IM B35
IM 3001/IM 2001
Mounting options

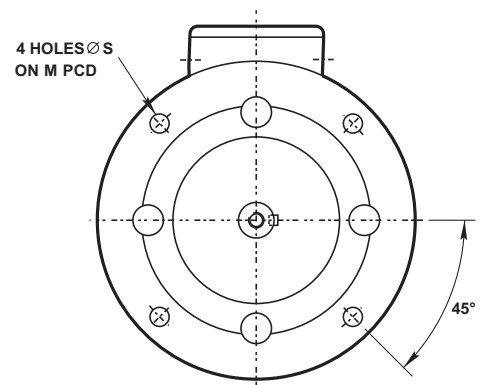
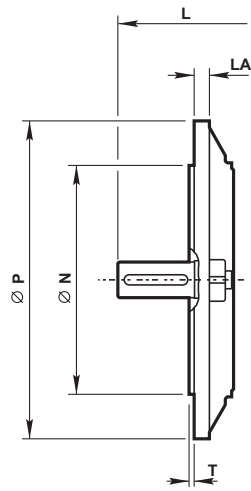

IM B14/IM B34
IM 3601/IM 2101
Mounting options

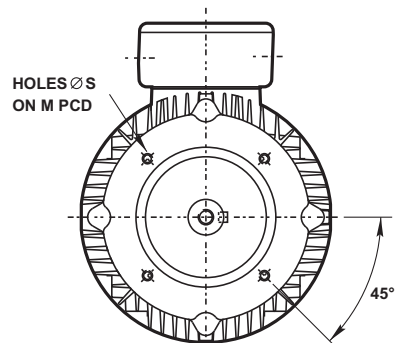
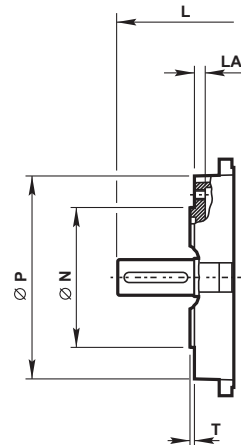

Foot, flange and face mounting - frame sizes 56 to 160 aluminium

| General | | | | | | | | | | | | | | | | |
|-----------|--------------|-----|-----|-----|-----------|-----|----|-----|-----|-----|----|-----|-------|-----|-----|---------|
| Type | Terminal box | | | | | | | | | | | | | | | |
| Aluminium | A | B | C | H | K | L | AA | AB | AC | BB | HA | HD | HE | TBW | TBH | KK |
| B-DA56M | 90 | 71 | 36 | 56 | 5.8 x 8.3 | 199 | 23 | 111 | 113 | 88 | 7 | 153 | 72 | 86 | 86 | 1 x M20 |
| B-DA63M | 100 | 80 | 40 | 63 | 7 x 9.5 | 217 | 24 | 123 | 120 | 100 | 7 | 166 | 78 | 101 | 101 | 1 x M20 |
| B-DA71M | 112 | 90 | 45 | 71 | 7 x 11 | 245 | 26 | 138 | 136 | 110 | 8 | 183 | 87 | 101 | 101 | 1 x M20 |
| B-DA80M | 125 | 100 | 50 | 80 | 10 x 14 | 287 | 35 | 157 | 155 | 125 | 9 | 205 | 102.5 | 101 | 101 | 1 x M25 |
| B-DA90S | 140 | 100 | 56 | 90 | 10 x 14 | 310 | 37 | 173 | 175 | 125 | 10 | 228 | 107.5 | 109 | 109 | 1 x M25 |
| B-DA90L | 140 | 125 | 56 | 90 | 10 x 14 | 335 | 37 | 173 | 175 | 150 | 10 | 228 | 107.5 | 109 | 109 | 1 x M25 |
| B-DA100L | 160 | 140 | 63 | 100 | 12 x 16 | 383 | 40 | 196 | 195 | 172 | 11 | 252 | 121.5 | 109 | 109 | 1 x M32 |
| B-DA112M | 190 | 140 | 70 | 112 | 12 x 16 | 401 | 41 | 227 | 219 | 180 | 12 | 294 | 147.5 | 119 | 119 | 2 x M32 |
| B-DA132S | 216 | 140 | 89 | 132 | 12 x 16 | 475 | 51 | 262 | 258 | 186 | 15 | 320 | 153.5 | 119 | 119 | 2 x M32 |
| B-DA132M | 216 | 178 | 89 | 132 | 12 x 16 | 513 | 51 | 262 | 258 | 224 | 15 | 320 | 153.5 | 119 | 119 | 2 x M32 |
| B-DA160M | 254 | 210 | 108 | 160 | 15 x 18 | 609 | 55 | 304 | 315 | 260 | 18 | 397 | 194.5 | 155 | 164 | 2 x M40 |
| B-DA160L | 254 | 254 | 108 | 160 | 15 x 18 | 653 | 55 | 304 | 315 | 304 | 18 | 397 | 194.5 | 155 | 164 | 2 x M40 |

| Flange & Face | | | | | | | | | | | | | | |
|---------------|----------------|-----|-----|------|-----|----|-----|-----------------|-----|-----|-----|----|--|--|
| Type | IM B5 mounting | | | | | | | IM B14 mounting | | | | | | |
| | M | N | P | S | T | LA | M | N | P | S | T | LA | | |
| B-DA56M | 100 | 80 | 120 | 7 | 3 | 8 | 65 | 50 | 80 | M5 | 2.5 | - | | |
| B-DA63M | 115 | 95 | 140 | 10 | 3 | 10 | 75 | 60 | 90 | M5 | 2.5 | - | | |
| B-DA71M | 130 | 110 | 160 | 10 | 3.5 | 10 | 85 | 70 | 105 | M6 | 2.5 | - | | |
| B-DA80M | 165 | 130 | 200 | 12 | 3.5 | 12 | 100 | 80 | 120 | M6 | 3.0 | - | | |
| B-DA90S | 165 | 130 | 200 | 12 | 3.5 | 11 | 115 | 95 | 140 | M8 | 3.0 | 14 | | |
| B-DA90L | 165 | 130 | 200 | 12 | 3.5 | 11 | 115 | 95 | 140 | M6 | 3.0 | 14 | | |
| B-DA100L | 215 | 180 | 250 | 14.5 | 4.0 | 13 | 130 | 110 | 160 | M8 | 3.5 | 15 | | |
| B-DA112M | 215 | 180 | 250 | 14.5 | 4.0 | 14 | 130 | 110 | 160 | M8 | 3.5 | 15 | | |
| B-DA132S | 265 | 230 | 300 | 14.5 | 4.0 | 14 | 165 | 130 | 200 | M10 | 3.5 | 17 | | |
| B-DA132M | 265 | 230 | 300 | 14.5 | 4.0 | 14 | 165 | 130 | 200 | M10 | 3.5 | 17 | | |
| B-DA160M | 300 | 250 | 350 | 18.5 | 5.0 | 15 | 215 | 180 | 250 | M12 | 4 | - | | |
| B-DA160L | 300 | 250 | 350 | 18.5 | 5.0 | 15 | 215 | 180 | 250 | M12 | 4 | - | | |

| Shaft | | | | | | | | |
|----------|----|-----|----|------|----|----|-----|-----|
| Type | D | E | F | G | GD | EB | ED | DH |
| B-DA56 | 9 | 20 | 3 | 7.2 | 3 | 16 | 2 | M4 |
| B-DA63 | 11 | 23 | 4 | 8.5 | 4 | 16 | 3.5 | M4 |
| B-DA71 | 14 | 30 | 5 | 11 | 5 | 25 | 2.5 | M5 |
| B-DA80 | 19 | 40 | 6 | 15.5 | 6 | 30 | 5 | M6 |
| B-DA90 | 24 | 50 | 8 | 20 | 7 | 40 | 5 | M8 |
| B-DA100 | 28 | 60 | 8 | 24 | 7 | 50 | 5 | M10 |
| B-DA112M | 28 | 60 | 8 | 24 | 7 | 50 | 5 | M10 |
| B-DA132 | 38 | 80 | 10 | 33 | 8 | 65 | 7.5 | M12 |
| B-DA160 | 42 | 110 | 12 | 37 | 8 | 90 | 10 | M16 |

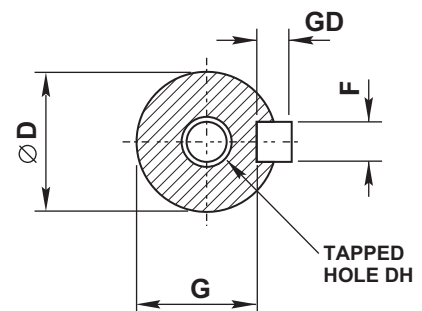

Dimensions

IE1

14

Foot and flange mounting - frame sizes 180 to 355 cast iron

IM B3
IM 1001
Mounting options

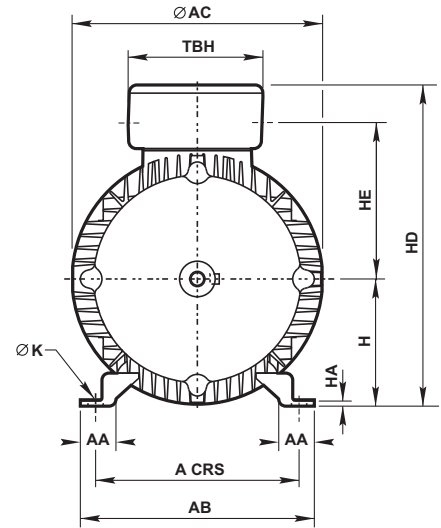
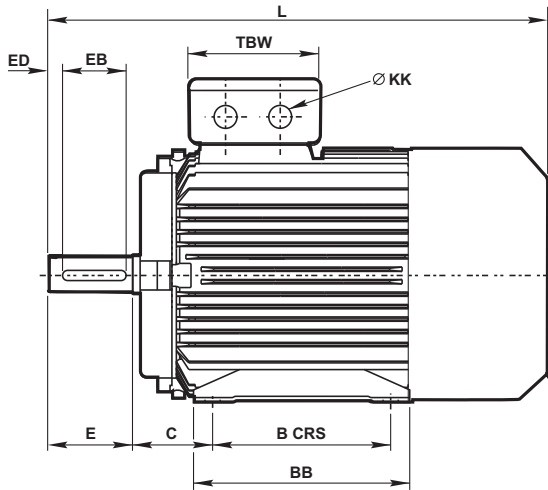

IM B5/IM B35
IM 3001/IM 2001
Mounting options

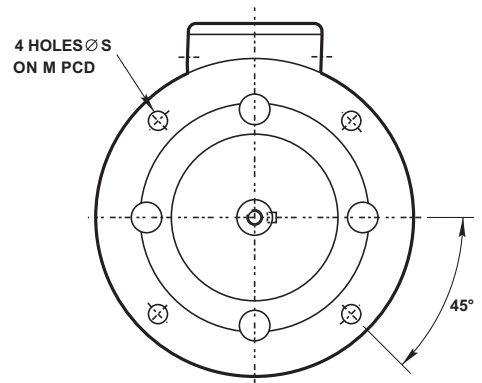
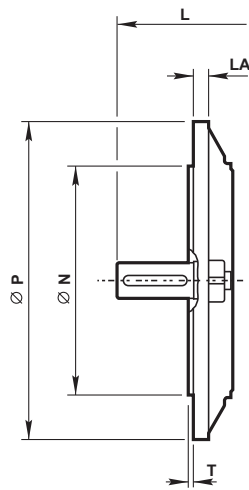

Up to 200 frame

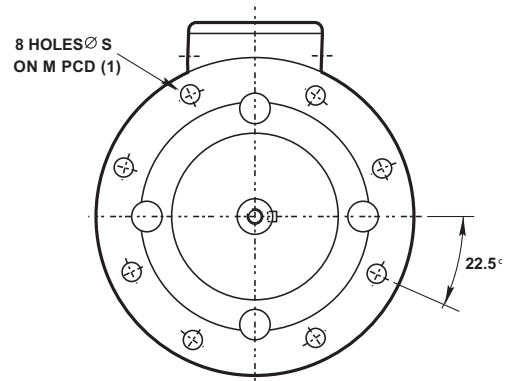

8 holes at 22.5° for flanges to suit 225 frames and above to European specification

Dimensions

IE1

15

Foot and flange mounting - frame sizes 180 to 355 cast iron

| General | | | | | | | | | | | | | | | | | | | |
|-----------|-----|-----|-----|-----|------|----------|------|--------|-----|-----|-----|----|-----|-------|-----|--------------|---------|-----|----|
| Type | | | | | | | | | | | | | | | | Terminal box | | | |
| Cast iron | A | B | C | H | K | 4 Pole + | | 2 Pole | | AA | AB | AC | BB | HA | HD | HE | TBW | TBH | KK |
| B-DF180M | 279 | 241 | 121 | 180 | 14.5 | 688 | 688 | 70 | 349 | 355 | 311 | 22 | 450 | 229 | 152 | 162 | 2 x M40 | | |
| B-DF180L | 279 | 279 | 121 | 180 | 14.5 | 726 | 726 | 70 | 349 | 355 | 349 | 22 | 450 | 229 | 152 | 162 | 2 x M40 | | |
| B-DF200L | 318 | 305 | 133 | 200 | 16.5 | 771 | 771 | 70 | 388 | 397 | 369 | 25 | 504 | 249 | 190 | 210 | 2 x M50 | | |
| BU-DF225S | 356 | 286 | 149 | 225 | 18.5 | 824 | - | 75 | 431 | 446 | 368 | 28 | 552 | 270 | 190 | 210 | 2 x M50 | | |
| BU-DF225M | 356 | 311 | 149 | 225 | 18.5 | 849 | 819 | 75 | 431 | 446 | 393 | 28 | 552 | 270 | 190 | 210 | 2 x M50 | | |
| BU-DF250M | 406 | 349 | 168 | 250 | 24 | 910 | 910 | 80 | 484 | 485 | 445 | 30 | 613 | 299 | 218 | 248 | 2 x M63 | | |
| BU-DF280S | 457 | 368 | 190 | 280 | 24 | 982 | 982 | 85 | 542 | 547 | 485 | 35 | 667 | 333 | 218 | 248 | 2 x M63 | | |
| BU-DF280M | 457 | 419 | 190 | 280 | 24 | 1033 | 1033 | 85 | 542 | 547 | 536 | 35 | 667 | 333 | 218 | 248 | 2 x M63 | | |
| BU-DF315S | 508 | 406 | 216 | 315 | 28 | 1208 | 1178 | 120 | 628 | 620 | 570 | 45 | 842 | 445 | 280 | 320 | 2 x M63 | | |
| BU-DF315M | 508 | 457 | 216 | 315 | 28 | 1318 | 1288 | 120 | 628 | 620 | 680 | 45 | 842 | 445 | 280 | 320 | 2 x M63 | | |
| BU-DF315L | 508 | 508 | 216 | 315 | 28 | 1318 | 1288 | 120 | 628 | 620 | 680 | 45 | 842 | 445 | 280 | 320 | 2 x M63 | | |
| BU-DF355M | 610 | 560 | 254 | 355 | 28 | 1556 | 1487 | 116 | 726 | 698 | 750 | 52 | 997 | 544.5 | 330 | 380 | 2 x M63 | | |
| BU-DF355L | 610 | 630 | 254 | 355 | 28 | 1556 | 1487 | 116 | 726 | 698 | 750 | 52 | 997 | 544.5 | 330 | 380 | 2 x M63 | | |

| Flange | | | | | | |
|---------------|------------------------|-----|-----|------|---|----|
| Type | IM B5, IM B35 mounting | | | | | |
| Cast iron | M | N | P | S | T | LA |
| B-DF180M/L | 300 | 250 | 350 | 18.5 | 5 | 15 |
| B-DF200L | 350 | 300 | 400 | 18.5 | 5 | 17 |
| BU-DF225S/M | 400 | 350 | 450 | 18.5 | 5 | 20 |
| BU-DF250 | 500 | 450 | 550 | 18.5 | 5 | 22 |
| BU-DF280 | 500 | 450 | 550 | 18.5 | 5 | 22 |
| BU-DF315S/M/L | 600 | 550 | 660 | 24 | 6 | 22 |
| BU-DF355M/L | 740 | 680 | 800 | 24 | 6 | 25 |

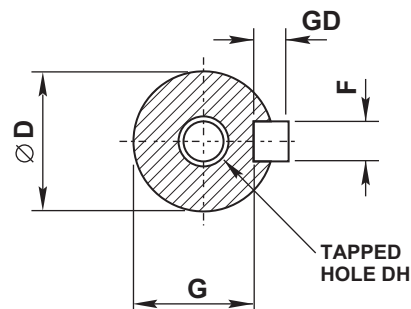

| Shaft | | | | | | | | | | | | | | | | |
|---------------|----------|-----|----|------|----|-----|-----|-----|--------|-----|----|------|----|-----|-----|-----|
| Type | 4 pole + | | | | | | | | 2 pole | | | | | | | |
| | D | E | F | G | GD | EB | ED | DH | D | E | F | G | GD | EB | ED | DH |
| B-DF180M/L | 48 | 110 | 14 | 42.5 | 9 | 90 | 10 | M16 | 48 | 110 | 14 | 42.5 | 9 | 90 | 10 | M16 |
| BU-DF200L | 55 | 110 | 16 | 49 | 10 | 100 | 5 | M20 | 55 | 110 | 16 | 49 | 10 | 100 | 5 | M20 |
| BU-DF225S | 60 | 140 | 18 | 53 | 11 | 125 | 7.5 | M20 | - | - | - | - | - | - | - | - |
| BU-DF225M | 60 | 140 | 18 | 53 | 11 | 125 | 7.5 | M20 | 55 | 110 | 16 | 49 | 10 | 100 | 5 | M20 |
| BU-DF250M | 65 | 140 | 18 | 58 | 11 | 125 | 7.5 | M20 | 60 | 140 | 18 | 53 | 11 | 125 | 7.5 | M20 |
| BU-DF280S/M | 75 | 140 | 20 | 67.5 | 12 | 125 | 7.5 | M20 | 65 | 140 | 18 | 58 | 11 | 125 | 7.5 | M20 |
| BU-DF315S/M/L | 80 | 170 | 22 | 71 | 14 | 160 | 5 | M20 | 65 | 140 | 18 | 58 | 11 | 125 | 7.5 | M20 |
| BU-DF355M/L | 100 | 210 | 28 | 90 | 16 | 200 | 5 | M24 | 75 | 140 | 20 | 67.5 | 12 | 125 | 7.5 | M20 |

Dimensions

IE2

16

Foot, flange and face mounting - frame sizes 80 to 160 aluminium

IM B3
IM 1001
Mounting options

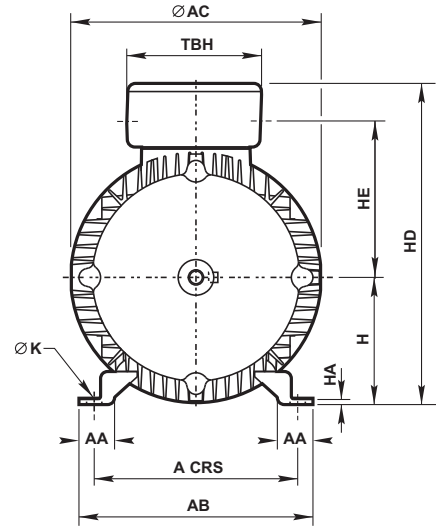
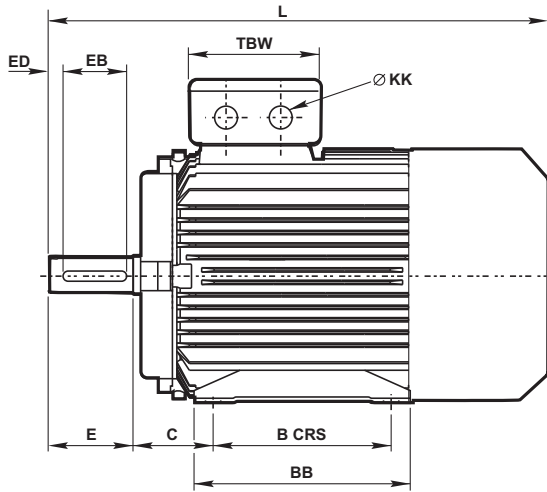

IM B5/IM B35
IM 3001/IM 2001
Mounting options

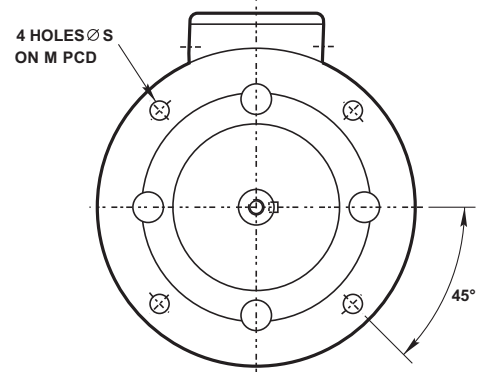
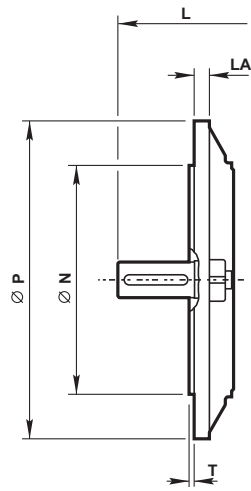

IM B14/IM B34
IM 3601/IM 2101
Mounting options

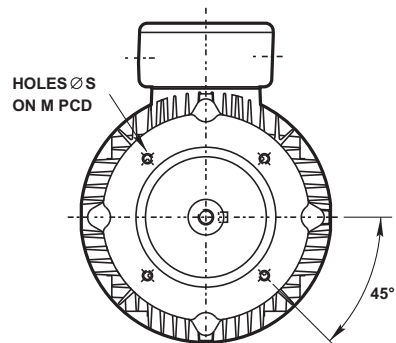
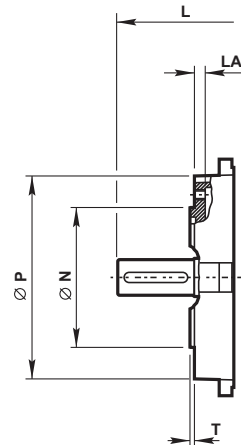

Foot, flange and face mounting - frame sizes 80 to 160 aluminium

| General | | | | | | | | | | | | | | | Terminal box | | |
|----------|-----|-----|-----|-----|---------|-----|----|-----|-----|-----|----|-----|-------|-----|--------------|---------|--|
| Type | A | B | C | H | K | L | AA | AB | AC | BB | HA | HD | HE | TBW | TBH | KK | |
| A-DA80M | 125 | 100 | 50 | 80 | 10 x 14 | 290 | 35 | 157 | 158 | 125 | 8 | 213 | 104 | 101 | 101 | 1 x M25 | |
| A-DA90S | 140 | 100 | 56 | 90 | 10 x 14 | 325 | 37 | 173 | 175 | 125 | 10 | 233 | 112 | 109 | 109 | 1 x M25 | |
| A-DA90L | 140 | 125 | 56 | 90 | 10 x 14 | 350 | 37 | 173 | 175 | 150 | 10 | 233 | 112 | 109 | 109 | 1 x M25 | |
| A-DA100L | 160 | 140 | 63 | 100 | 12 x 16 | 398 | 40 | 196 | 198 | 172 | 11 | 260 | 124 | 109 | 109 | 1 x M32 | |
| A-DA112M | 190 | 140 | 70 | 112 | 12 x 16 | 440 | 41 | 227 | 219 | 180 | 12 | 281 | 135 | 119 | 119 | 2 x M32 | |
| A-DA132S | 216 | 140 | 89 | 132 | 12 x 16 | 475 | 51 | 262 | 258 | 186 | 15 | 320 | 153.5 | 119 | 119 | 2 x M32 | |
| A-DA132M | 216 | 178 | 89 | 132 | 12 x 16 | 513 | 51 | 262 | 258 | 224 | 15 | 320 | 153.5 | 119 | 119 | 2 x M32 | |
| A-DA160M | 254 | 210 | 108 | 160 | 15 x 18 | 609 | 55 | 304 | 315 | 260 | 18 | 402 | 194.5 | 155 | 164 | 2 x M40 | |
| A-DA160L | 254 | 254 | 108 | 160 | 15 x 18 | 653 | 55 | 304 | 315 | 304 | 18 | 402 | 194.5 | 155 | 164 | 2 x M40 | |

| Flange & Face | | | | | | | | | | | | | |
|---------------|----------------|-----|-----|------|-----|----|-----------------|-----|-----|-----|-----|----|--|
| Type | IM B5 mounting | | | | | | IM B14 mounting | | | | | | |
| | M | N | P | S | T | LA | M | N | P | S | T | LA | |
| A-DA80M | 165 | 130 | 200 | 12 | 3.5 | 12 | 100 | 80 | 120 | M6 | 3.0 | - | |
| A-DA90S | 165 | 130 | 200 | 12 | 3.5 | 11 | 115 | 95 | 140 | M8 | 3.0 | 14 | |
| A-DA90L | 165 | 130 | 200 | 12 | 3.5 | 11 | 115 | 95 | 140 | M6 | 3.0 | 14 | |
| A-DA100L | 215 | 180 | 250 | 14.5 | 4.0 | 13 | 130 | 110 | 160 | M8 | 3.5 | 15 | |
| A-DA112M | 215 | 180 | 250 | 14.5 | 4.0 | 14 | 130 | 110 | 160 | M8 | 3.5 | 15 | |
| A-DA132S | 265 | 230 | 300 | 14.5 | 4.0 | 14 | 165 | 130 | 200 | M10 | 3.5 | 17 | |
| A-DA132M | 265 | 230 | 300 | 14.5 | 4.0 | 14 | 165 | 130 | 200 | M10 | 3.5 | 17 | |
| A-DA160M | 300 | 250 | 350 | 18.5 | 5.0 | 15 | 215 | 180 | 250 | M12 | 4 | - | |
| A-DA160L | 300 | 250 | 350 | 18.5 | 5.0 | 15 | 215 | 180 | 250 | M12 | 4 | - | |

| Shaft | | | | | | | | |
|----------|----|-----|----|------|----|----|-----|-----|
| Type | D | E | F | G | GD | EB | ED | DH |
| A-DA80 | 19 | 40 | 6 | 15.5 | 6 | 30 | 5 | M6 |
| A-DA90 | 24 | 50 | 8 | 20 | 7 | 40 | 5 | M8 |
| A-DA100 | 28 | 60 | 8 | 24 | 7 | 50 | 5 | M10 |
| A-DA112M | 28 | 60 | 8 | 24 | 7 | 50 | 5 | M10 |
| A-DA132 | 38 | 80 | 10 | 33 | 8 | 65 | 7.5 | M12 |
| A-DA160 | 42 | 110 | 12 | 37 | 8 | 90 | 10 | M16 |

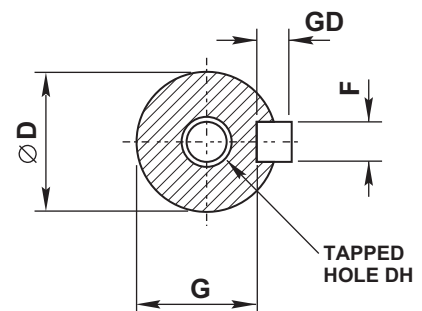

Foot and flange mounting - frame sizes 180 to 355 cast iron

IM B3
IM 1001
Mounting options

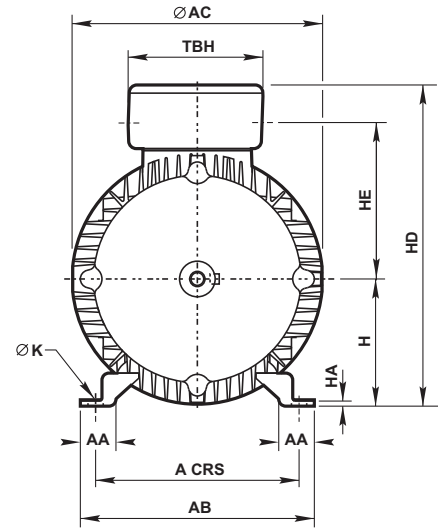
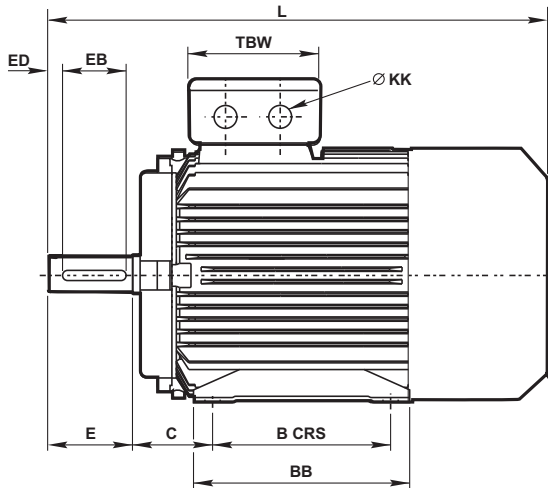

IM B5/IM B35
IM 3001/IM 2001
Mounting options

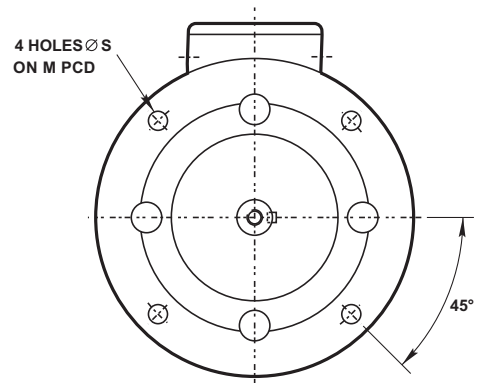
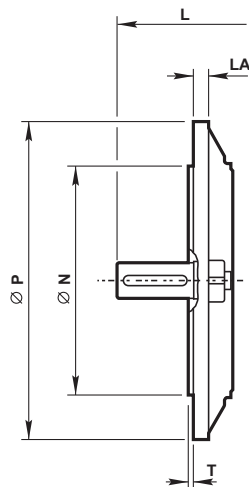

Up to 200 frame

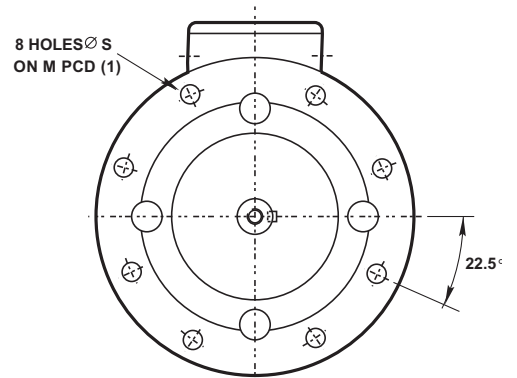

8 holes at 22.5° for flanges to suit 225 frames and above to European specification

Foot and flange mounting - frame sizes 180 to 355 cast iron

| General | | | | | | | | | | | | | | | | | | | |
|-----------|-----|-----|-----|-----|------|----------|------|--------|-----|-----|-----|----|-----|-------|--------------|-----|---------|-----|----|
| Type | | | | | | | | | | | | | | | Terminal box | | | | |
| Cast iron | A | B | C | H | K | 4 Pole + | | 2 Pole | | AA | AB | AC | BB | HA | HD | HE | TBW | TBH | KK |
| A-DF180M | 279 | 241 | 121 | 180 | 14.5 | 688 | 688 | 70 | 349 | 355 | 311 | 22 | 450 | 226.5 | 152 | 162 | 2 x M40 | | |
| A-DF180L | 279 | 279 | 121 | 180 | 14.5 | 726 | 726 | 70 | 349 | 355 | 349 | 22 | 450 | 226.5 | 152 | 162 | 2 x M40 | | |
| A-DF200L | 318 | 305 | 133 | 200 | 16.5 | 779 | 771 | 70 | 388 | 397 | 369 | 25 | 504 | 249 | 190 | 210 | 2 x M50 | | |
| AU-DF225S | 356 | 286 | 149 | 225 | 18.5 | 824 | - | 75 | 431 | 446 | 368 | 28 | 561 | 278 | 190 | 210 | 2 x M50 | | |
| AU-DF225M | 356 | 311 | 149 | 225 | 18.5 | 849 | 819 | 75 | 431 | 446 | 393 | 28 | 561 | 278 | 190 | 210 | 2 x M50 | | |
| AU-DF250M | 406 | 349 | 168 | 250 | 24 | 910 | 910 | 80 | 484 | 485 | 445 | 30 | 610 | 303 | 218 | 248 | 2 x M63 | | |
| AU-DF280S | 457 | 368 | 190 | 280 | 24 | 982 | 982 | 85 | 542 | 547 | 485 | 35 | 669 | 333 | 218 | 248 | 2 x M63 | | |
| AU-DF280M | 457 | 419 | 190 | 280 | 24 | 1033 | 1033 | 85 | 542 | 547 | 536 | 35 | 669 | 333 | 218 | 248 | 2 x M63 | | |
| AU-DF315S | 508 | 406 | 216 | 315 | 28 | 1224 | 1194 | 120 | 628 | 620 | 570 | 45 | 842 | 445 | 280 | 320 | 2 x M63 | | |
| AU-DF315M | 508 | 457 | 216 | 315 | 28 | 1334 | 1304 | 120 | 628 | 620 | 680 | 45 | 842 | 445 | 280 | 320 | 2 x M63 | | |
| AU-DF315L | 508 | 508 | 216 | 315 | 28 | 1334 | 1304 | 120 | 628 | 620 | 680 | 45 | 842 | 445 | 280 | 320 | 2 x M63 | | |
| AU-DF355M | 610 | 560 | 254 | 355 | 28 | 1556 | 1487 | 116 | 726 | 698 | 750 | 52 | 997 | 540 | 330 | 380 | 2 x M63 | | |
| AU-DF355L | 610 | 630 | 254 | 355 | 28 | 1556 | 1487 | 116 | 726 | 698 | 750 | 52 | 997 | 540 | 330 | 380 | 2 x M63 | | |

| Flange | | | | | | |
|---------------|------------------------|-----|-----|------|---|----|
| Type | IM B5, IM B35 mounting | | | | | |
| Cast iron | M | N | P | S | T | LA |
| A-DF180M/L | 300 | 250 | 350 | 18.5 | 5 | 15 |
| A-DF200L | 350 | 300 | 400 | 18.5 | 5 | 17 |
| AU-DF225S/M | 400 | 350 | 450 | 18.5 | 5 | 20 |
| AU-DF250 | 500 | 450 | 550 | 18.5 | 5 | 22 |
| AU-DF280 | 500 | 450 | 550 | 18.5 | 5 | 22 |
| AU-DF315S/M/L | 600 | 550 | 660 | 24 | 6 | 22 |
| AU-DF355M/L | 740 | 680 | 800 | 24 | 6 | 25 |

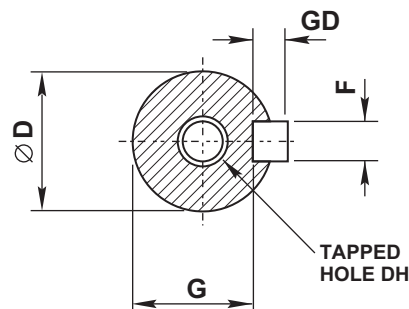

| Shaft | | | | | | | | | | | | | | | | | |
|---------------|----------|-----|----|------|----|-----|-----|-----|--------|-----|----|------|----|-----|-----|-----|--|
| Type | 4 pole + | | | | | | | | 2 pole | | | | | | | | |
| Cast iron | D | E | F | G | GD | EB | ED | DH | D | E | F | G | GD | EB | ED | DH | |
| A-DF180M/L | 48 | 110 | 14 | 42.5 | 9 | 90 | 10 | M16 | 48 | 110 | 14 | 42.5 | 9 | 90 | 10 | M16 | |
| AU-DF200L | 55 | 110 | 16 | 49 | 10 | 100 | 5 | M20 | 55 | 110 | 16 | 49 | 10 | 100 | 5 | M20 | |
| AU-DF225S | 60 | 140 | 18 | 53 | 11 | 125 | 7.5 | M20 | - | - | - | - | - | - | - | - | |
| AU-DF225M | 60 | 140 | 18 | 53 | 11 | 125 | 7.5 | M20 | 55 | 110 | 16 | 49 | 10 | 100 | 5 | M20 | |
| AU-DF250M | 65 | 140 | 18 | 58 | 11 | 125 | 7.5 | M20 | 60 | 140 | 18 | 53 | 11 | 125 | 7.5 | M20 | |
| AU-DF280S/M | 75 | 140 | 20 | 67.5 | 12 | 125 | 7.5 | M20 | 65 | 140 | 18 | 58 | 11 | 125 | 7.5 | M20 | |
| AU-DF315S/M/L | 80 | 170 | 22 | 71 | 14 | 160 | 5 | M20 | 65 | 140 | 18 | 58 | 11 | 125 | 7.5 | M20 | |
| AU-DF355M/L | 100 | 210 | 28 | 90 | 16 | 200 | 5 | M24 | 75 | 140 | 20 | 67.5 | 12 | 125 | 7.5 | M20 | |

Dimensions

20

Foot and flange mounting - frame sizes 355LB to 450 cast iron

IM B3
IM 1001
Mounting options

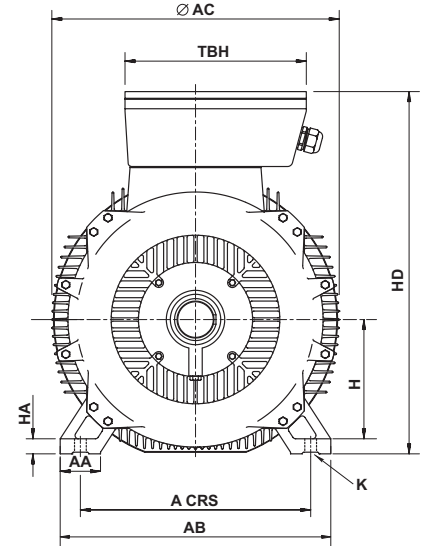

IM B35
IM 2001
Mounting options

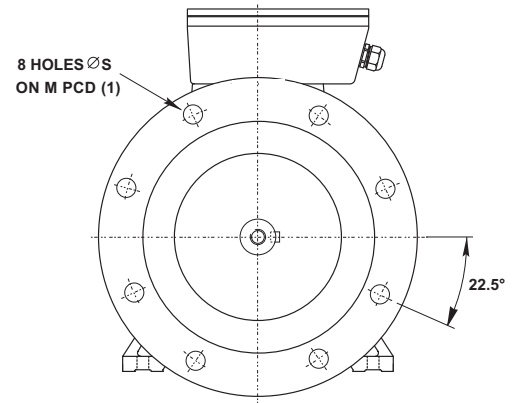
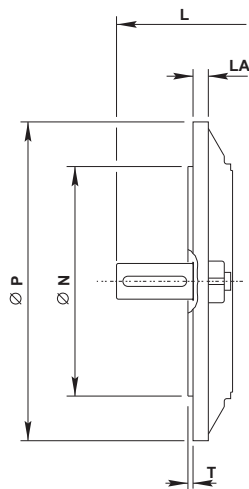

Dimension

Foot and flange mounting - frame sizes 355LB to 450 cast iron

| General | | | | | | | | | | | | | | | | | | |
|-------------|-----|-----|------|-----|-----|----|----------------|-------------|-------------|-----|-----|-----|------|----|--------------|-----|-----|---------|
| Type | | | | | | | | | | | | | | | Terminal box | | | |
| Cast iron | A | B1 | B2 | C | H | K | 6, 8 Pole L | 4 Pole L | 2 Pole L | AA | AB | AC | BB | HA | HD | TBW | TBH | KK |
| BU-DF355B + | 630 | 800 | - | 224 | 355 | 35 | 1918 | 1898 | 1863 | 116 | 760 | 745 | 1140 | 52 | 1120 | 392 | 572 | 3 x M63 |
| BU-DF400M | 686 | 630 | 710 | 280 | 400 | 36 | 1881 | 1881 | 1820 | 120 | 806 | 860 | 1090 | 52 | 1080 | 430 | 485 | 3 x M63 |
| BU-DF400L | 686 | 630 | 710 | 280 | 400 | 36 | 1881 | 1881 | 1820 | 120 | 806 | 860 | 1090 | 55 | 1080 | 430 | 485 | 3 x M63 |
| BU-DF450M | 800 | 900 | 1000 | 250 | 450 | 36 | 2200 | 2200 | 2050 | 150 | 950 | 950 | 1200 | 62 | 1400 | 460 | 530 | 3 x M63 |
| BU-DF450L | 800 | 900 | 1000 | 250 | 450 | 36 | 2200 | 2200 | 2050 | 150 | 950 | 950 | 1200 | 62 | 1400 | 460 | 530 | 3 x M63 |

| Flange | | | | | | |
|-----------|------------------------|-----|------|----|---|----|
| Type | IM B5, IM B35 mounting | | | | | |
| Cast iron | M | N | P | S | T | LA |
| BU-DF355 | 840 | 780 | 800 | 24 | 6 | - |
| BU-DF400 | 940 | 880 | 1000 | 28 | 6 | - |
| BU-DF450 | 1040 | 980 | 1100 | 32 | 8 | - |

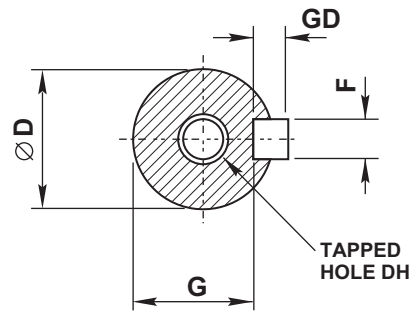

| Shaft | | | | | | | | | | | | | | | | | |
|----------|----------|-----|----|-----|----|-----|----|-----|--------|-----|----|------|----|-----|----|-----|--|
| Type | 4 pole + | | | | | | | | 2 pole | | | | | | | | |
| | D | E | F | G | GD | EB | ED | DH | D | E | F | G | GD | EB | ED | DH | |
| BU-DF355 | 110 | 210 | 28 | 86 | 16 | 160 | 5 | M24 | 80 | 170 | 22 | 67.5 | 14 | 130 | 5 | M20 | |
| BU-DF400 | 110 | 210 | 28 | 100 | 16 | 180 | 15 | M24 | 85 | 170 | 22 | 76 | 14 | 140 | 15 | M24 | |
| BU-DF450 | 130 | 250 | 32 | 119 | 16 | 180 | 15 | M24 | 90 | 170 | 25 | 86 | 14 | 140 | 15 | M24 | |

Dimension pages notes & mounting codes

| Shaft | | |
|-----------|-----|------------------|
| Dim D | Tol | Limits |
| 11 to 14 | j6 | +0.008 -0.003 |
| 19 to 28 | j6 | +0.009 -0.004 |
| 38 to 48 | k6 | +0.018 +0.002 |
| 55 to 80 | m6 | +0.030 +0.011 |
| 85 to 110 | m6 | +0.035 +0.013 |

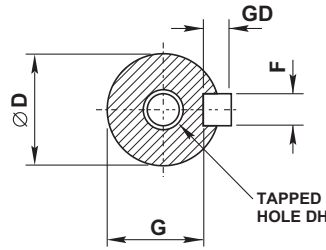

All dimensions in millimetres

Cable entry can be arranged in any one of four positions at 90° intervals

Dimensions should not be used for installation purposes unless specially endorsed

B5 mounted motors have suffix '-D' in the frame reference, eg A-DA132MA-D and B3/B5 mounted motors have suffix '-H' in the frame reference, eg A-DA132MA-H

B14 mounted motors have suffix 'C' in the frame reference, eg A-DA132MA-C and B3/B14 mounted motors have suffix '-H' in the frame reference, eg A-DA132MA-H

Note

355LB frame and above, flange only available when B35 mounted (foot & flange).

| Flange | | |
|------------|-----------|------------------|
| Dim N | IEC 60072 | |
| | Tol | Limits |
| 110 | j6 | +0.013 -0.009 |
| 130 | j6 | +0.014 -0.011 |
| 230 to 250 | j6 | +0.016 -0.013 |
| 300 | j6 | +0.016 -0.016 |
| 350 | j6 | +0.018 -0.018 |
| 450 | j6 | +0.020 -0.020 |
| 550 | j6 | +0.022 -0.022 |
| 680 | js6 | +0.025 -0.025 |

| Face | | |
|------------|-----------|------------------|
| Dim N | IEC 60072 | |
| | Tol | Limits |
| 70 and 80 | j6 | +0.012 -0.007 |
| 95 and 110 | j6 | +0.013 -0.009 |
| 130 | j6 | +0.014 -0.011 |
| 230 | j6 | +0.016 -0.013 |

Mounting codes

Horizontal shaft:

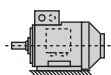

**IM B3
IM 1001**
foot mounted

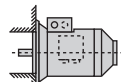

**IM B5
IM 3001**
flange at DE
no feet



**IM B6
IM 1051**
foot wall mounted with
feet on left-hand side
when viewed from DE



**IM B7
IM 1061**
foot wall mounted with
feet on right-hand side
when viewed from DE



**IM B8
IM 1071**
ceiling mounted
with feet
above motor

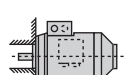

**IM B14
IM 3601**
face at DE
no feet

Vertical shaft:

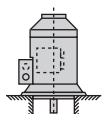

**IM V1
IM 3011**
flange at DE
shaft down
no feet

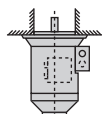

**IM V3
IM 3031**
flange at DE
shaft up
no feet

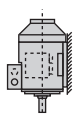

**IM V5
IM 1011**
vertical foot
wall mounted
shaft down

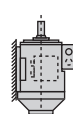

**IM V6
IM 1031**
vertical foot
wall mounted
shaft up

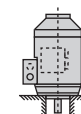

**IM V18
IM 3611**
face at DE
shaft down
no feet

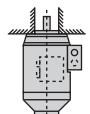

**IM V19
IM 3631**
face at DE
shaft up
no feet

Bearing arrangements

| Bearing references and oilseals for horizontally mounted motors only | | | | | | |
|--|-------------------|-------|-------------------------|---------------|-------------------------|----------------|
| Type | | Poles | Bearings ⁽¹⁾ | | Oilseals ⁽²⁾ | |
| Aluminium | Cast iron | | Drive end | Non-drive end | Drive end | Non-drive end |
| B / A-DA56 | – | All | 6201ZZ | 6201ZZ | 12 x 25 x 7 | 12 x 25 x 7 |
| B / A-DA63M | – | All | 6201ZZ | 6201ZZ | 12 x 25 x 7 | 12 x 25 x 7 |
| B / A-DA71M | – | All | 6202ZZ | 6202ZZ | 15 x 30 x 7 | 15 x 30 x 7 |
| B / A-DA80M | – | All | 6204ZZ | 6204ZZ | 20 x 35 x 7 | 20 x 35 x 7 |
| B / A-DA90S/L | – | All | 6205ZZ | 6205ZZ | 25 x 40 x 7 | 25 x 40 x 7 |
| B / A-DA100L | – | All | 6206ZZ | 6206ZZ | 30 x 47 x 7 | 30 x 47 x 7 |
| B / A-DA112M | – | All | 6206ZZ | 6206ZZ | 30 x 47 x 7 | 30 x 47 x 7 |
| B / A-DA132S/M | – | All | 6208ZZ | 6208ZZ | 40 x 62 x 7 | 40 x 62 x 7 |
| B / A-DA160M/L | – | All | 6309ZZ | 6309ZZ | 45 x 62 x 12 | 45 x 62 x 12 |
| – | B / A-DF180M/L | All | 6311 | 6311 | 55 x 75 x 12 | 55 x 75 x 12 |
| – | B / A-DF200L | All | 6312 | 6312 | 60 x 80 x 12 | 60 x 80 x 12 |
| – | B / AU-DF225S/M | All | 6313 | 6313 | 65 x 90 x 12 | 60 x 90 x 12 |
| – | B / AU-DF250S/M | All | 6314 | 6314 | 70 x 90 x 12 | 70 x 90 x 12 |
| – | B / AU-DF280S/M | 2 | 6314 | 6314 | 70 x 90 x 12 | 70 x 90 x 12 |
| – | B / AU-DF280S/M | 4 up | 6317 | 6317 | 85 x 110 x 12 | 85 x 110 x 12 |
| – | B / AU-DF315S/M/L | 2 | 6317 | 6317 | 85 x 110 x 12 | 85 x 110 x 12 |
| – | B / AU-DF315S/M/L | 4 up | NU / 6319 | 6319 | 95 x 120 x 12 | 95 x 120 x 12 |
| – | B / AU-DF355M/L | 2 | 6319 | 6319 | 95 x 120 x 12 | 95 x 120 x 12 |
| – | B / AU-DF355M/L | 4 up | NU322 | 6322 | 110 x 140 x 14 | 110 x 140 x 14 |
| – | BU-DF400 | 2 | NU2194E & 6219 | 7219B | 84.5 x 97 x 10 | 84.5 x 97 x 10 |
| – | BU-DF400 | 4 up | NU326E | 6326 | 119 x 140 x 14 | 119 x 140 x 14 |
| – | BU-DF450 | 2 | NU222E & 6222 | 7222B | 110 x 124 x 12 | 110 x 124 x 12 |
| – | BU-DF450 | 4 up | 6328 | 6328 | 140 x 154 x 15 | 140 x 154 x 15 |

⁽¹⁾ Frame sizes 56-160 have sealed for life bearings with C3 clearances. Frame sizes 180-355 have bearings with C3 clearance.

⁽²⁾ Sizes given are in mm and represent bore x outside diameter x width.
The seal material used on all frame sizes and all polarity is nitrile rubber (NBR).

BROOK CROMPTON

Brook Crompton
St Thomas' Road Huddersfield
West Yorkshire HD1 3LJ UK
Tel: +44 (0) 1484 557200
Fax: +44 (0) 1484 557201
E-mail: csc@brookcrompton.com
Internet: www.brookcrompton.com

Every care has been taken to ensure the accuracy of the information contained in this publication, but, due to a policy of continuous development and improvement the right is reserved to supply products which may differ slightly from those illustrated and described in this publication

